

High Amperage Heavy Duty Circuit Breaker

143

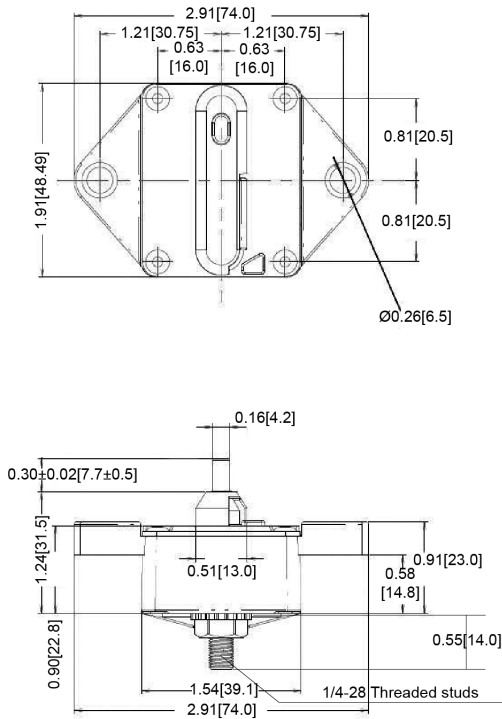

Mechanical Dimensions: Inches [mm]



Unless Otherwise Specified All Dimensions Have a Tolerance of ±.008in (0.2mm)

Part Numbers Information

Optifuse P/N	Current
143025	25A
143030	30A
143040	40A
143050	50A
143060	60A
143070	70A
143080	80A
143090	90A
143100	100A
143120	120A
143135	135A
143150	150A
143180	180A
143200	200A

Time vs. Percent of Rated Current

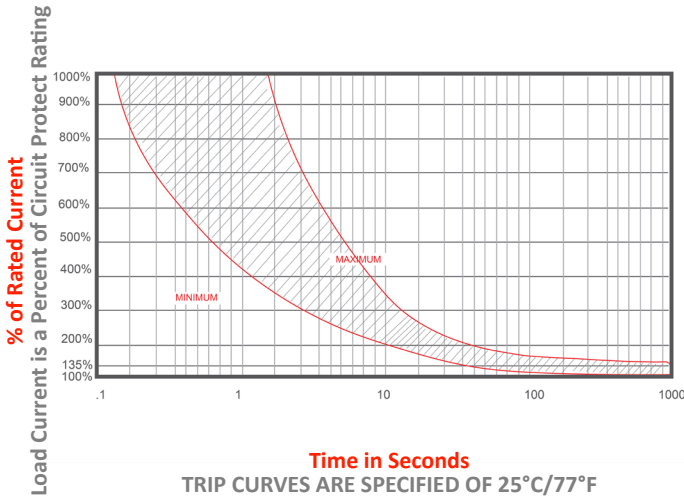

% of Rated Current	Min Hold Time	Max Hold Time
100%	No Trip (≥ 30 Minutes)	
135%	50s	30m
200%	12s	45s
300%	3.5s	15s

Trip time: Ambient temperature 25°C ± 3°C

Electrical Specifications

Voltage Rating	42VDC; 48VDC
Reset Type	Type III - Manual Reset
Interrupting Rating	3000A @ 30VDC (ABYC E-11) 1500A @ 48VDC 3000A @ 44VDC
Operation Temperature	-25 °F ~ 180 °F -32 °C ~ 82 °C
Testing	SAE J1625, IEC 60934

Material Specifications

Heavy Duty High Amp - Waterproof Circuit Breaker	
Body Material	Thermoset Plastic (UL94V-0)
Terminals Material	Nickel Plated
Terminals Configuration	1/4"-28 Stud
Studs Torque	10.3 N.m max.
Mounting Type	Panel Mount
Ignition Protected	SAE J1171
Ingress Protection	IP67

High Amperage Heavy Duty Circuit Breaker

143



Rev	Date of issue	Revision Notes	Designed	Approved
E	10-13-2025	Voltage Rating, Interrupting Rating Changed	RC	OF