

Mechanical Dimensions: Inches [mm]

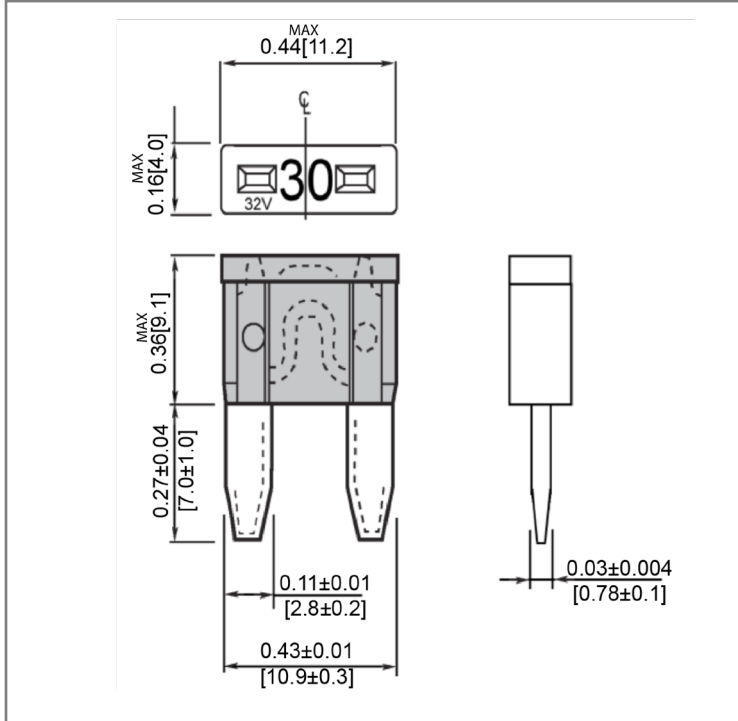

Retail Pack: Inches [mm]

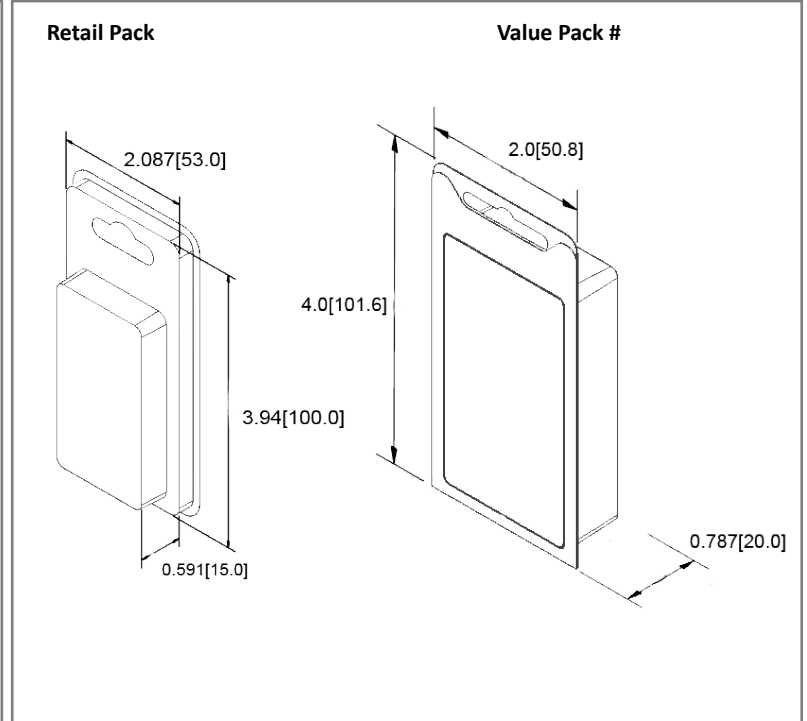

Part Numbers Information

Amperage	Body Color	Bulk Part #	Retail Pack # Blister Card	Pack Size	Value Pack # Clamshell	Pack Size
2A	Gray	ANM-2A	ANM-2A-BP	5	ANM-2A-VP	25
3A	Violet	ANM-3A	ANM-3A-BP	5	ANM-3A-VP	25
4A	Pink	ANM-4A	ANM-4A-BP	5	ANM-4A-VP	25
5A	Tan	ANM-5A	ANM-5A-BP	5	ANM-5A-VP	25
7.5A	Brown	ANM-7.5A	ANM-7.5A-BP	5	ANM-7.5A-VP	25
10A	Red	ANM-10A	ANM-10A-BP	5	ANM-10A-VP	25
15A	Blue	ANM-15A	ANM-15A-BP	5	ANM-15A-VP	25
20A	Yellow	ANM-20A	ANM-20A-BP	5	ANM-20A-VP	25
25A	Clear	ANM-25A	ANM-25A-BP	5	ANM-25A-VP	25
30A	Green	ANM-30A	ANM-30A-BP	5	ANM-30A-VP	25

Electrical Specifications

Voltage Rating	32V DC
Interrupting Rating	1000A @ 32 VDC
Testing	SAE J2077; ISO 8820-3
Operating Temperature	-40 °C ~ 105 °C

Material Specifications

Body	PA 66
Terminals	Zinc Alloy

Time vs. Percent of Rated Current Curve

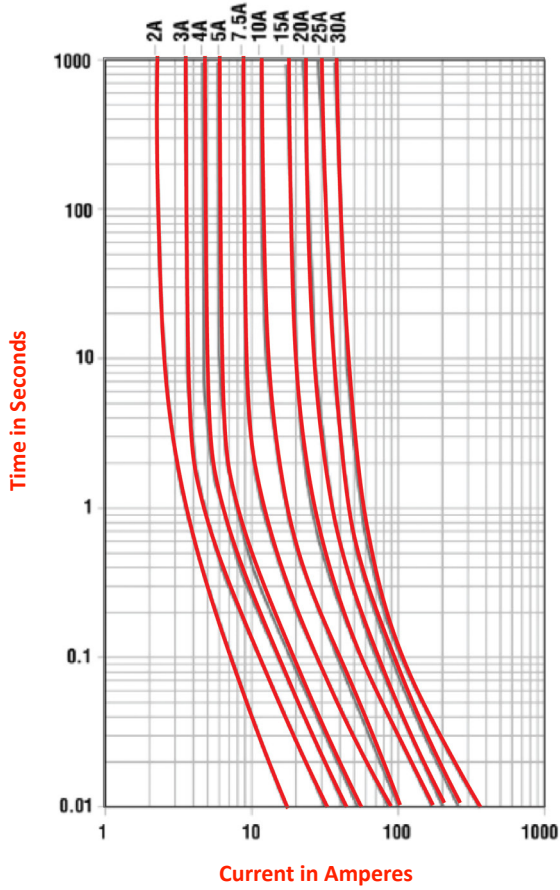

% of Rated Current	Current Rating	Min Hold Time	Max Hold Time
110%	2-30 Amp	100 hrs	-
135%	2-30 Amp	-	1800s
200%	2-30 Amp	-	5s

Rev Date of issue Revision Notes

Designed Approved

C	07-19-2024	Updated Testing Information	RC	OF
---	------------	-----------------------------	----	----