

Recommended Erection Instructions for Steel Frames

1 Scope

1.1 Recommended methods for the installation of steel frames for swinging doors in a variety of wall conditions, commonly used in commercial buildings, are covered within this standard. The installation of transom/sidelight (or panel) type frames and single or multiple borrowed lights are not covered in this standard.

1.1.1 It is not the intention of this document to obstruct the development of alternative installation methods, nor is it intended to restrict frame installation solely to the wall types noted herein.

1.1.2 Although this document is commonly referenced for severe windstorm installations, critical performance requirements (such as type, quantity, and location of anchors) shall be as indicated in the manufacturer's published Approvals or Listings.

1.2 Reference documents

SDI 127E-2006 (R2021), *Prime Painted Materials Alert*

SDI 127F-2019, *Butted Frames Rough Opening Sizes*

SDI 127J-2010 (R2018), *Back Coating of Frames*

SDI 117-2019, *Manufacturing Tolerances for Standard Steel Doors and Frames*

NFPA 80-2022, *Standard for Fire Doors and Other Opening Protectives* (National Fire Protection Association, 1 Batterymarch Park, Quincy, MA 02269; www.nfpa.org)

UL10C-2009 (R2021), *Standard for Safety Positive Pressure Fire Tests of Door Assemblies*

ANSI/SDI A250.8-2017, *Recommended Specifications for Standard Doors and Frames*

HMMA 840-16, *Installation and Storage of Hollow Metal Doors and Frames*

HMMA 841-13, *Tolerances and Clearances for Commercial Hollow Metal Doors and Frames*

1.2.1 Further information on wall construction, anchoring, details, manufacturing tolerances or installation may be found in the following:

SDI 110-2018, *Standard Steel Doors and Frames for Modular Masonry Construction*

SDI 111-A-H, *Recommended Standard Details for Steel Doors, Frames, Accessories and Related Components*

SDI 122-2015, *Installation and Troubleshooting Guide for Standard Steel Doors and Frames*

SDI 127D-2006 (R2019), *Electric Strikes in Stud Walls*

1.3 Metrication

1.3.1 Standard dimensions used in this document are in inch-pound units. Metric values, where applicable, are included in parenthesis for reference only. These are "soft conversion" approximates.

Values stated without parentheses are the requirement. Values in parentheses are explanatory or approximate information.

1.4 Notes

1.4.1 Tolerances

Note: All values which do not carry specific tolerances or are not marked maximum or minimum shall have the following tolerances: Linear dimensions shall be $\pm 1/16$ in. (1.6 mm). Weight or force shall be $\pm 2\%$. Angles shall be ± 2 degrees. Where only minus tolerances are given, the dimensions are permitted to be exceeded at the option of the manufacturers.

1.4.2 Gauge vs. Thickness

While the term 'gauge' is no longer common for defining material thickness it is still used to

specify doors and frames for ordering purposes. The term 'thickness' is used when defining the actual dimension of an item, and the term 'gauge' is used in the context of specifying a particular door or frame.

1.4.3 Frame Installation in Cast-In-Place Concrete Walls

While the use of hollow metal frames in cast-in-place concrete walls is a common construction practice, the SDI does not recommend the inclusion of the frame as part of the process of pouring the wall. Instead, a rough-opening should be blocked out no less than 3/16" (4.8 mm) larger than the frame on all three sides. For example the opening for a 3' 0" x 7' 0" standard frame with 2" faces would be 3' 4-3/8" x 7' 2-3/16" minimum. The installer is responsible for anchoring the frame per the manufacturer's installation instructions, shimming and aligning as necessary.

2 Storage and Preliminary Assembly

(see SDI 127E, and ANSI/SDI A250.8)

2.1 All frames, including knocked-down, shall be stored under cover.

2.1.1 Knocked-down frames shall be placed flat on at least 4" (102 mm) wood sills to prevent the frames from resting on the ground.

2.1.2 Assembled frames shall be stored vertically. The units shall be placed on at least 4" (102 mm) high wood sills or in a manner that will prevent rust or damage.

2.1.3 Non-vented plastic or canvas shelters that can create a humidity chamber shall not be used.

2.1.4 Refer to project specifications for required cleanup and touchup work.

2.2 Back Coating (see SDI 127J for further information)

2.2.1 When temperature conditions necessitate the use of anti-freezing agents in plaster or mortar, the inside of the frame shall be coated

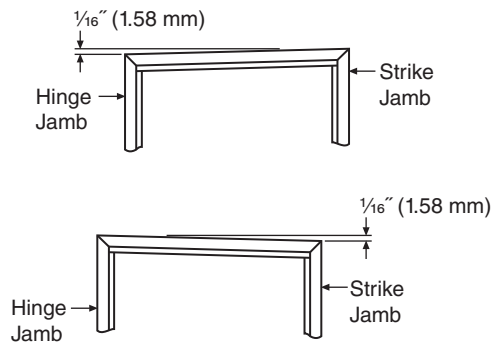

Maximum 1/16" allowable tolerance on total opening.

1a – Squareness

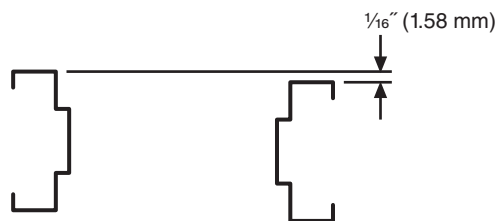

1c – Alignment

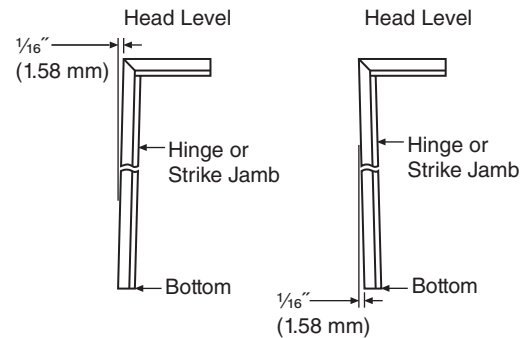

1b – Plumbness

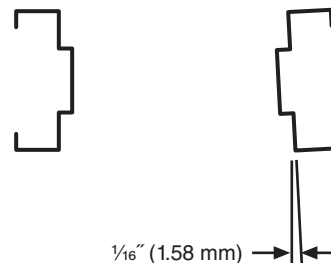

1d – Twist

Figure 1 – Examples of the accuracy to be maintained while setting frames

at the jobsite with a corrosion resistant coating by the contractor responsible for installation.

2.3 Grouting of frames (see ANSI/SDI A250.8 for further information)

2.3.1 Where grouting is required in masonry installations, frames shall be braced or fastened in such a way that will prevent the pressure of the grout from deforming the frame members.

2.3.2 Grout shall be mixed to provide a 4" (102 mm) maximum slump consistency (self-consolidating grout), and be hand troweled into place. Grout mixed to a thinner "pumpable" consistency shall not be used.

2.3.3 Standard mortar protection in frames is not intended for thin consistency grout. Steel frames, including fire-rated frames, do not require grouting. Grouting is not recommended for frames installed in drywall.

2.4 Assembly of frame/anchor provisions

2.4.1 Follow manufacturers' recommended procedure for assembly of frame and quantity and spacing of anchors. If not indicated, install anchors at hinge levels and directly opposite at strike jamb.

2.5 Verification

2.5.1 Prior to installation, jobsite personnel shall ensure correct swing, size and labeling.

2.6 Installation tolerances

2.6.1 Openings will not function properly if the frame is not installed within recognized tolerances.

Figure 1 shows examples of the accuracy to be maintained while setting frames.

3 Plumbing and bracing frames

3.1 Wood Spreaders (see Figure 2)

The Contractor(s) responsible for installation shall have available a sufficient supply of wood spreaders for bracing frames. Spreader bars

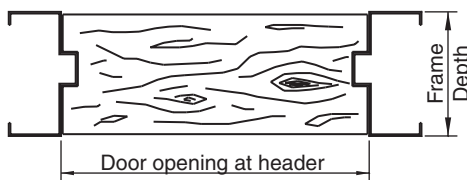

Figure 2 – Spreader

for shipping purposes shall not be used as installation spreaders.

3.1.1 Wood spreaders shall be square and fabricated from lumber no less than 1" (25.4 mm) thick. Correct length is the door opening width between the jambs at the header (i.e., Single Door 3'-0" = 36" = 915 mm). Length tolerance is +1/16", -0" (+1.6 mm, -0). Cut clearance notches for frame stops. Spreader shall be nearly as wide as frame jamb depth for proper installation.

3.2 Equipment for plumbing the frame (see Figure 3)

3.2.1 The contractor should be equipped with a carpenter level, square and wood spreaders.

3.2.2 Where welded frames are provided with spreader bars, they shall be removed with a suitable saw or chisel and filed flush before setting frames. Any bare metal surfaces shall be retouched with suitable primer.

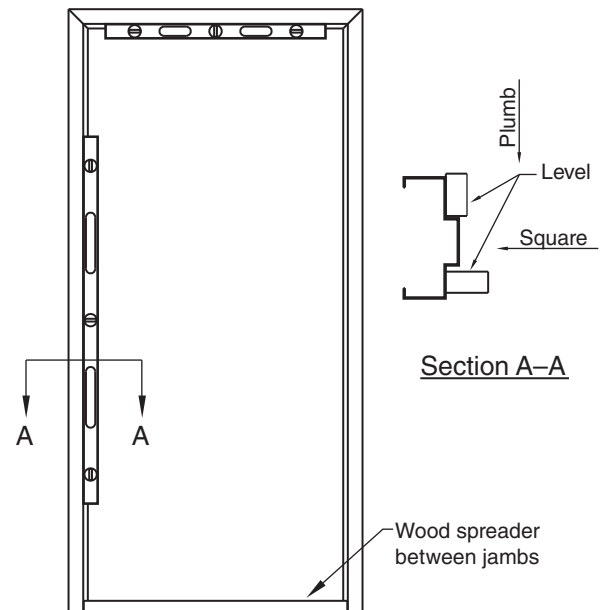

Figure 3 – Plumbing the frame

3.3 Bracing the frame (see Figure 4)

3.3.1 Frame bracing shall be as shown or shore to a structure above.

3.3.2 Bracing shall be perpendicular to the intended wall.

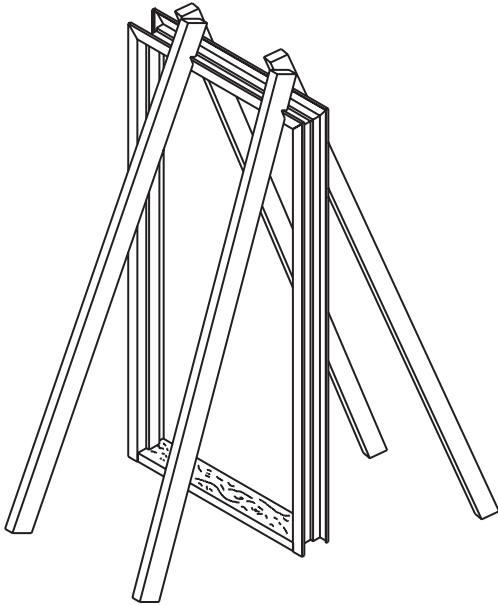

Figure 4 – Bracing the frame

3.4 Positioning the frame

3.4.1 Set the frame in the desired location and level the header. Square jamba to header. Shim under jamba if necessary. With frame properly aligned, insert wood spreaders at bottom and mid-height and fasten jamba to floor through floor anchors.

3.4.2 Plumb and square jamba. Install vertical brace to support header for openings over 4'-0" (1219 mm) wide.

3.4.3 Do not remove spreaders until wall is erected and cured.

4 Accessories

4.1 Install rubber silencers where required (see Figure 5)

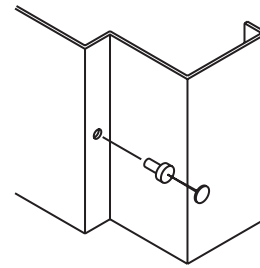

Figure 5 – Rubber silencers

4.1.1 Install rubber silencers before frame erection to avoid grout filling rubber silencer holes. In some cases rubber silencers are factory installed.

4.1.2 Cut the point from a #6d box or finishing nail. Insert nail in hole to elongate rubber silencers.

Moisten the end and insert rubber silencers in predrilled holes on frame stop, remove nail. The thickness of the silencer shall permit latching of door with $\frac{1}{16}$ " to $\frac{3}{32}$ " (1.6 to 2.4 mm) clearance between face of door and stop of frame.

4.2 Extended base anchor (see Figure 6)

4.2.1 Extended base anchors are supplied upon request only. (If required for tool attachment.)

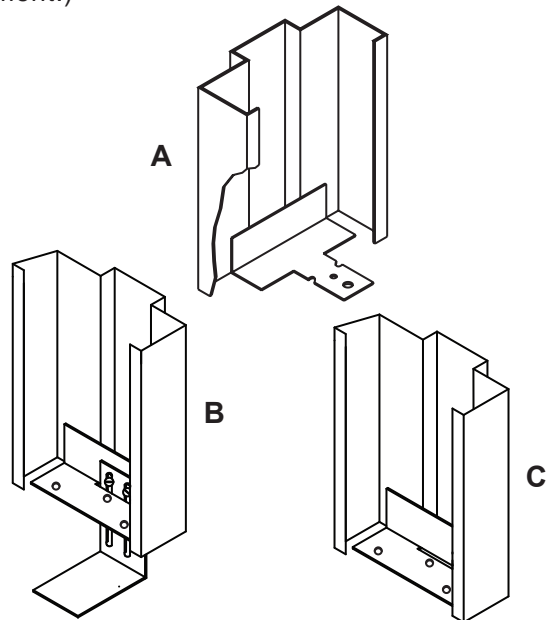

Figure 6 – Extended base anchor

5 New masonry construction (see Figure 7)

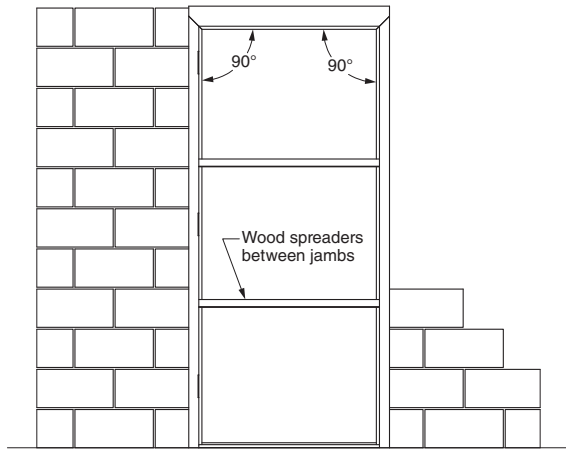

Figure 7 – New masonry construction

5.1 Assemble frame per manufacturer’s instructions.

5.2 Erect, brace, square and plumb frame.

5.2.1 Fasten frame to floor through base anchors.

5.3 Set second spreader at the mid-height of the door opening to maintain the door opening size. See Annex B for proper spacing of spreaders.

5.4 Install anchors (See Figure 8). Utilize mortar in the area of all anchors ensuring each anchor is embedded into the masonry joint. When grouting of frames is specified or required, adhere to the project specifications listed therein (See SDI’s *Risks of Grouting Hollow Metal Frames* at www.steeldoor.org).

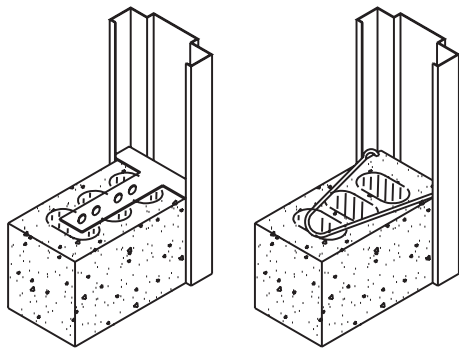

Figure 8 – Masonry anchors

5.4.1 Frames may also be supplied with anchors welded in place.

5.5 Continually check plumb and square as wall progresses.

6 Existing masonry construction
(see Figure 9, Figure 10, and SDI 127F)

6.1 Rough openings for existing wall, structural steel framing, or retrofit installations utilizing a butted to wall application shall be no less

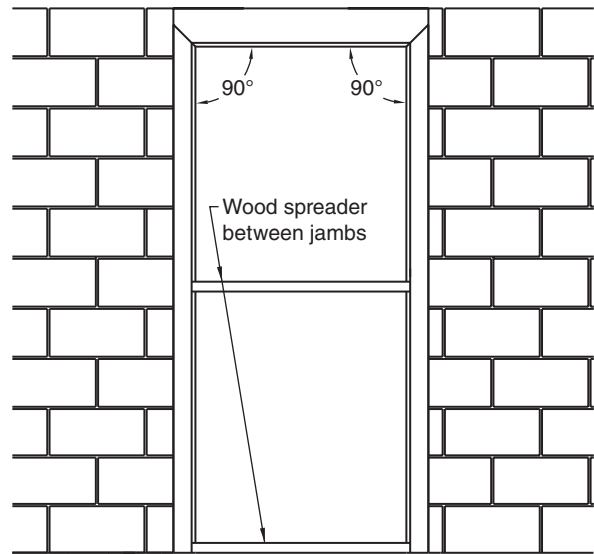

Figure 9 – Existing masonry construction

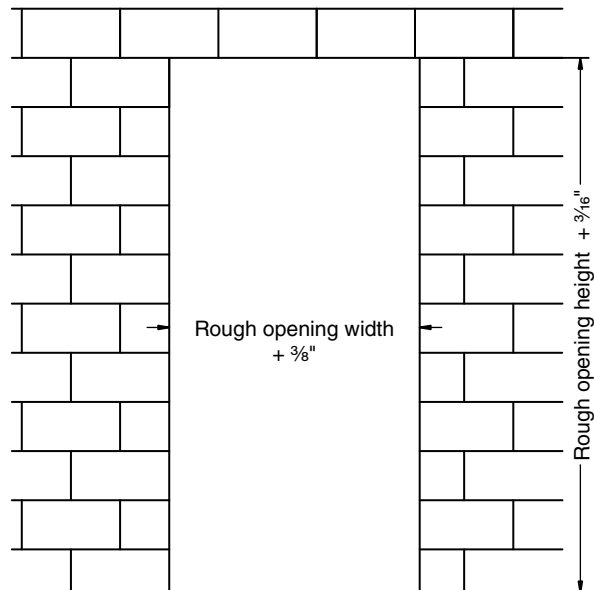

Figure 10 – Rough Opening

than $\frac{3}{16}$ " (4.8 mm) larger than the frame on all three sides.

6.1.1 The installer is responsible for any shimming or aligning required. Gaps are normally sealed as part of the installation or sealant/painting process.

6.1.2 Refer to architectural specifications for the appropriate sealant material to be used at fire or smoke control doors.

6.2 Assemble frame per manufacturer's instructions.

6.3 Install snap-in anchors (see Figure 11) and tap with a hammer to align with pierced holes in jambs.

6.3.1 Frames may also be supplied with anchors welded in place.

6.4 Slide frame into wall opening; install wood spreaders.

6.5 Where needed, use shims between the wall and frame at the location of anchors and spreaders to maintain squareness and alignment of frame, and to maintain door opening sizes.

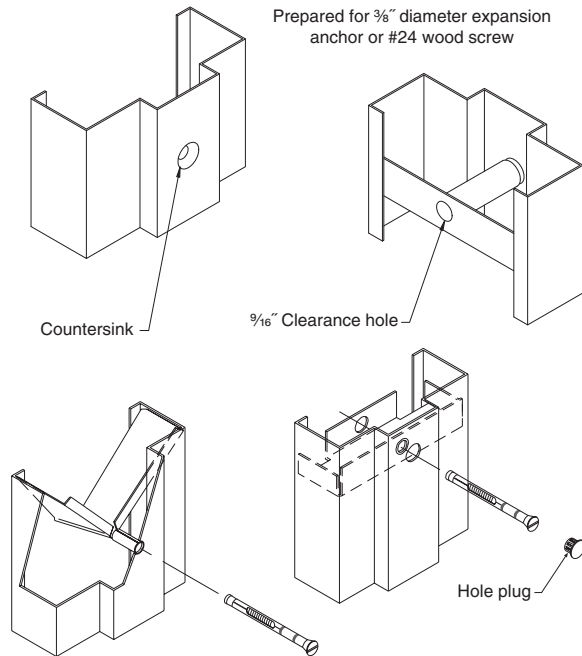

Figure 11 – Existing masonry or concrete wall anchors

6.5.1 Drill appropriate size hole (per fastener manufacturer's instructions) for one-piece anchor bolts. Leave holes "rough" for added grip.

6.6 Insert anchor bolts and tighten securely, checking for frame alignment periodically.

6.7 Install plugs to cover bolt heads (if so equipped).

6.8 Backer rod and/or sealant shall be used where gaps occur between frame and wall.

7 Steel stud wall construction, studs erected with frame (see Figure 12)

7.1 Assemble frame per manufacturer's instructions.

7.2 Install snap-in anchors. Position anchors in frame through the throat and tap in with a hammer.

7.2.1 Frames may also be supplied with anchors welded in place.

7.3 Erect, brace, square and plumb frame as shown.

7.4 Install wood spreaders.

7.5 Attach jambs to floor through floor anchor.

7.6 Install jamb studs to floor, header channels, and ceiling runners butted tightly against

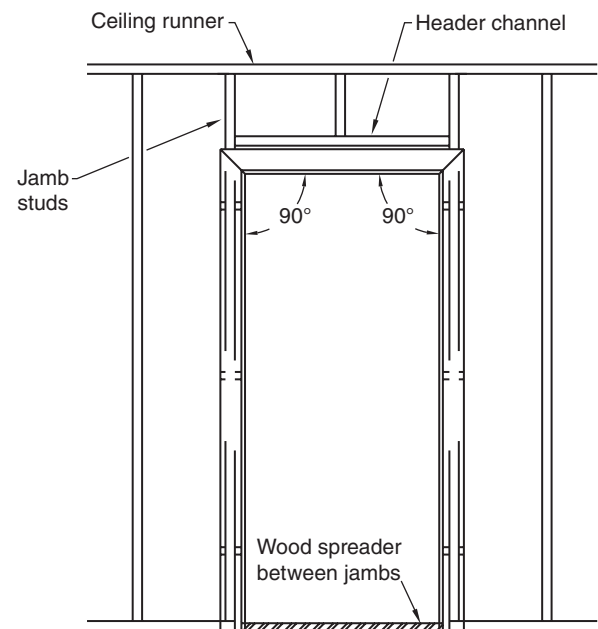

Figure 12 – Steel stud wall construction

frame anchors and properly positioned in frame throat for wallboard.

7.6.1 Nesting or overlapping stud joints or other wall construction practices that will increase the overall wall thickness beyond the intended finished thickness are to be avoided.

7.7 Attach jamb studs to anchors with screws or weld.

7.7.1 If using screws, drill from the back side of the stud, through both the stud and anchor, then attach with (2) screws per anchor location (see Figure 13). Screws shall be #6 x $\frac{3}{8}$ " minimum steel sheet metal or self-tapping type.

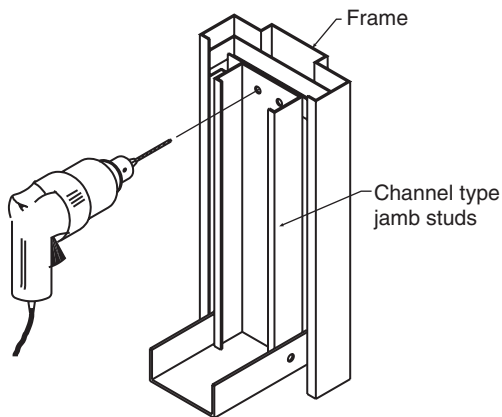

Figure 13 – Channel type steel stud

7.7.2 When attaching header stud to jamb studs, be sure the stud is above frame header. This will assure ample room for attaching plaster lath or drywall and will not interfere with installation of hardware attached to frame header.

7.7.3 At wrap-around installations in fire-rated walls, drywall shall extend at least $\frac{1}{2}$ " (12.7 mm) into frame throat. See Section 12 for frame installations in butted or existing stud walls.

8 Double egress frames in steel stud wall construction

8.1 Generally, the installation of double egress frames in steel stud walls follows the same procedure as Section 7.

8.1.1 If frames are supplied knocked down, assemble per manufacturer's instructions.

8.1.2 Install anchors (if not supplied welded to frame) per manufacturer's instructions.

8.2 Erect, brace, square and plumb frame as shown (see Figure 14).

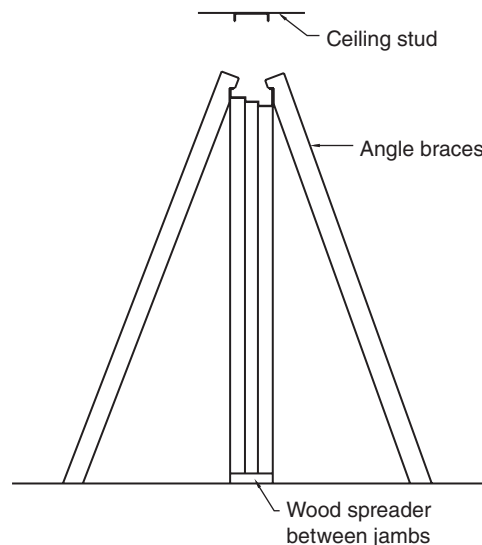

Figure 14 – Erect frame

8.2.1 Stand frame up in desired location. Anchor one jamb to floor and set wood spreader on floor from anchored jamb to loose jamb.

8.2.2 Install a vertical wood brace at center of frame.

8.2.3 Position and anchor second jamb to floor. Plumb, level and square frame, then install wood spreaders at mid-height.

8.3 Anchor jambs (see Figure 15)

8.3.1 Install jamb studs to floor, header channels, and ceiling runners butted tightly against frame anchors and properly positioned in frame throat for wallboard.

8.3.2 Nesting or overlapping stud joints or other wall construction practices that will increase the overall wall thickness beyond the intended finished thickness are to be avoided.

8.4 Attach jamb studs to anchors with screws or weld.

8.4.1 If using screws, drill from the back side of the stud, through both the stud and anchor, then attach with (2) screws per anchor location (see figure 15). Screws shall be #6 x $\frac{3}{8}$ " minimum steel sheet metal or self-tapping type.

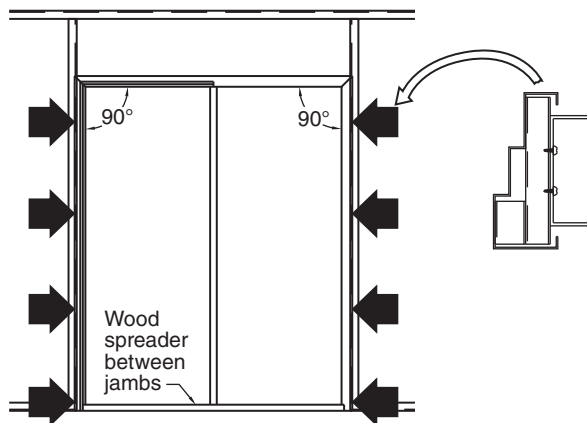

Figure 15 – Anchor jambs

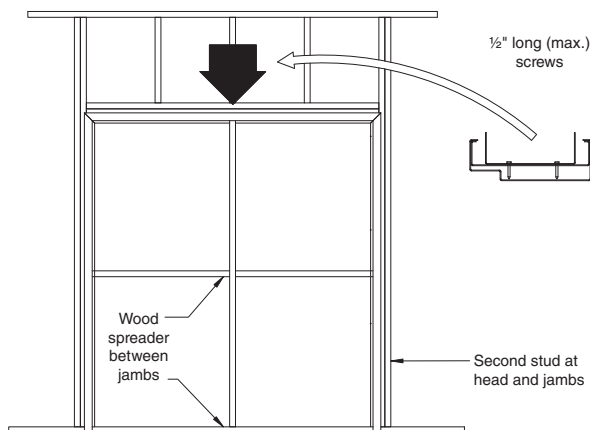

Figure 16 – Anchor header

8.5 Anchor header (see Figure 16)

Header anchor requirements will vary. The manufacturer's installation requirements should be followed.

8.6 At wrap-around installations in fire-rated walls, drywall shall extend at least $\frac{1}{2}$ " (12.7 mm) into frame throat. See Section 12 for frame installations in butted or existing stud walls.

9 Wood stud construction (studs erected with frame)

9.1 Assemble frame per manufacturer's instructions.

9.2 Install snap-in anchors. Position anchors in frame through the throat and tap in with a hammer.

9.2.1 Frames may also be supplied with anchors welded in place.

9.3 Square, brace and plumb frame as shown (see Figure 17).

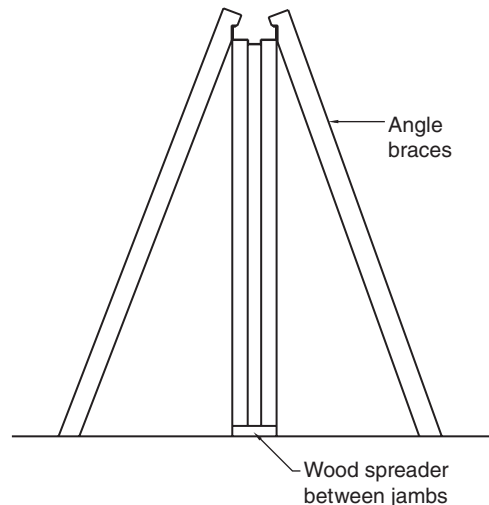

Figure 17 – Erect frame

- 9.4 Install wood spreaders (see Figure 18).
- 9.5 Attach jambs to floor through floor anchor.
- 9.6 Install jamb studs (jack stud and king stud) butted tightly against anchors and properly positioned in frame throat for wallboard (see Figure 18).
- 9.6.1 Attach header stud(s) or header assembly between jamb studs making sure they are above the frame head. This will assure ample

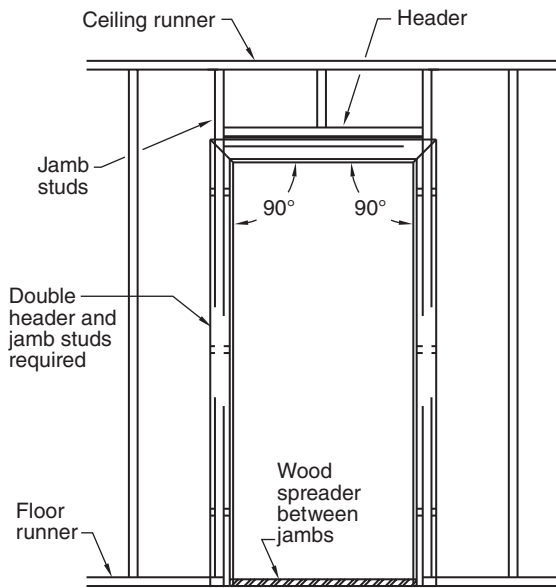

Figure 18 – Wood stud wall construction

room for attaching plaster lath or drywall and will not interfere with installation of hardware attached to frame head (see Figure 18).

- 9.7 Bend anchor straps around stud leaving sufficient clearance between frame return and stud for inserting finished wall material (see Figure 19, Figure 20 and Figure 21).

- 9.7.1 If there is insufficient room for wall finish, notch jamb studs no more than 1/16" (1.6 mm) deep for anchor straps.

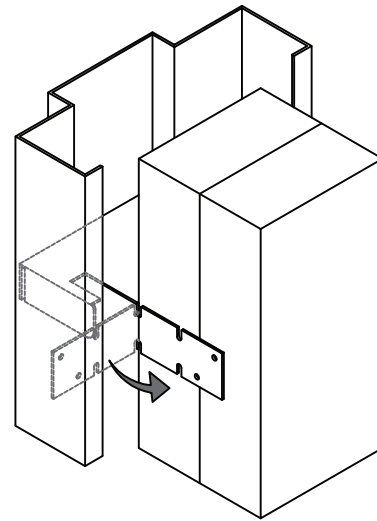

Figure 20 – Snap or weld in anchors wood/steel studs

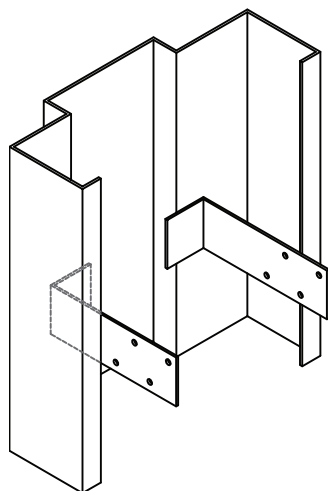

Figure 19 – Weld in strap anchors wood/steel studs

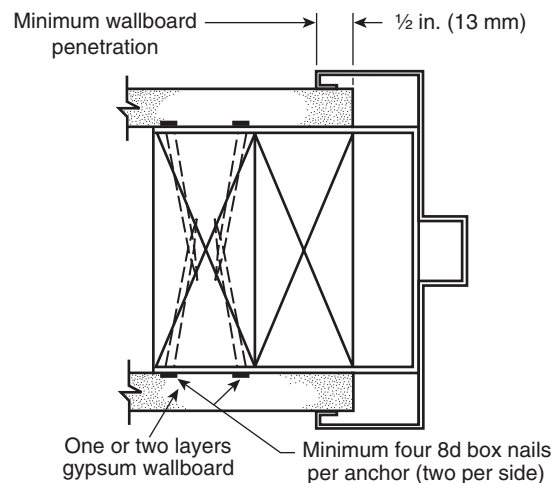

Figure 21 – Hollow metal steel door frame with wood stud anchors

9.8 Square and nail top anchor to stud on ONE JAMB ONLY. Check plumb and square and continue to nail balance of anchors to stud. Repeat for opposite jamb. For steel studs install screws from back of stud into Z anchor (see Figure 22).

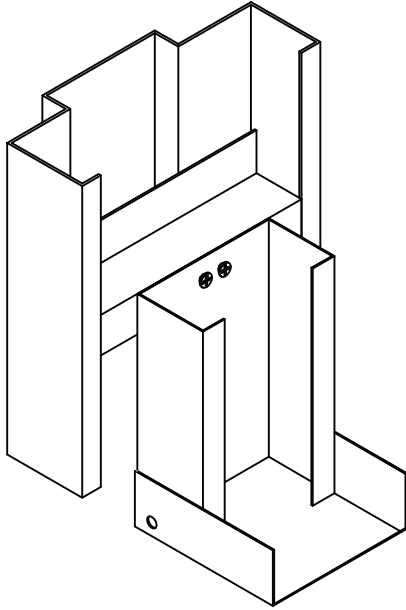

Figure 22 – Z Type weld in anchors steel studs

9.8.1 At wrap-around installations in fire-rated walls, at least one layer of drywall on each side shall extend a minimum of 1/2" (12.7 mm) into the frame throat. See Figure 23-A, B and C.

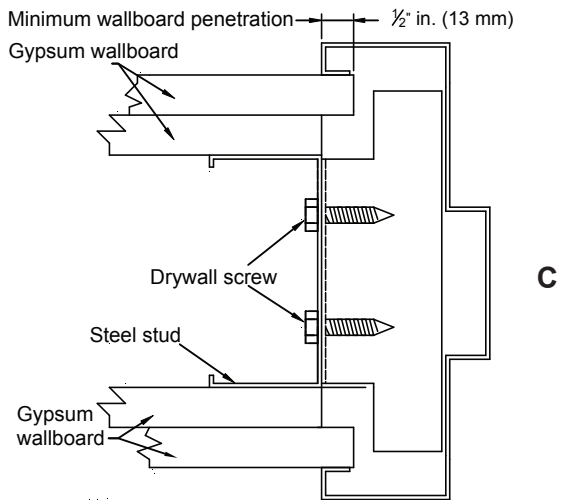
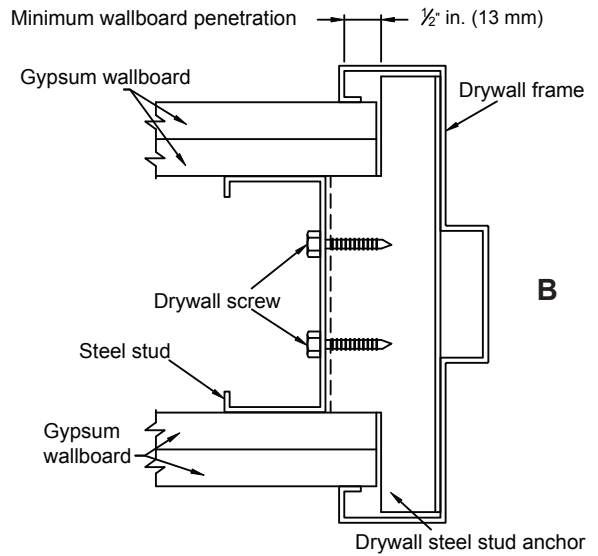
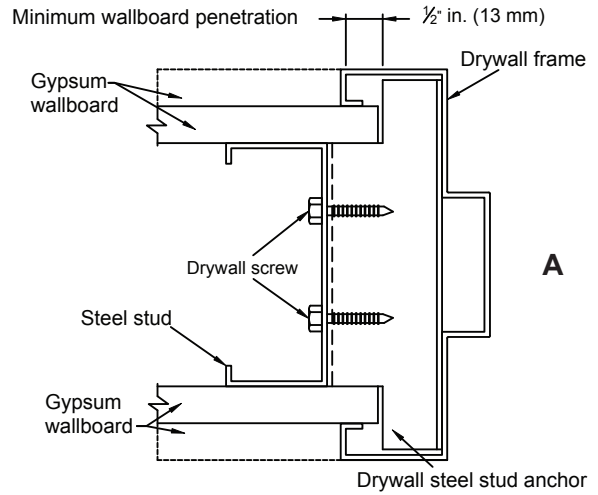

Figure 23 – Hollow metal door frame with steel stud anchors

10 Wood/steel stud construction (studs erected before frame)

10.1 Build rough opening (see Figure 24) according to dimensions and clearances in frame manufacturer's installation instructions.

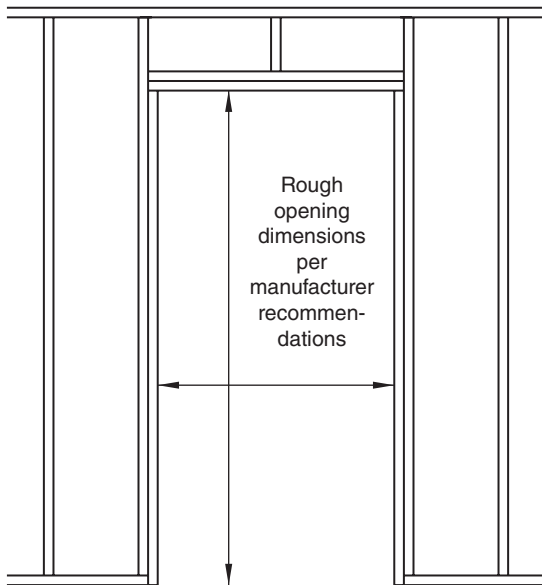

Figure 24 – Rough opening shown in wood stud

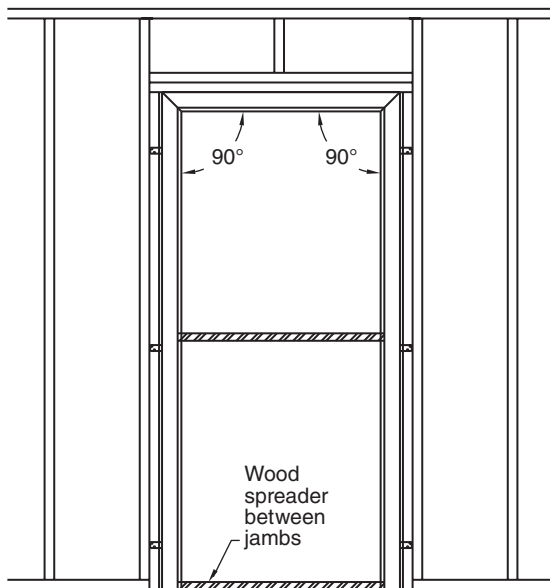

Figure 25 – Wood stud wall construction

10.1.1 Assure that rough openings are no less than those required in SDI 127F.

10.1.2 It is recommended that double studs be used at jambs and headers.

10.2 Assemble frame per manufacturer's instructions.

10.3 Install snap-in anchors. Position anchors in frame through the throat and tap in with a hammer.

10.3.1 Frames may also be supplied with anchors welded in place.

10.3.2 If base anchors cannot be used add one anchor per jamb at bottom.

10.3.3 Install fire-rated frames with the anchor quantity and spacing as per the individual manufacturer's listings and instructions.

10.4 Slide frame into wall opening.

10.4.1 Install wood spreaders at bottom and mid-height. Square and level frame. Shim jambs if necessary (see Figure 25).

10.5 Bend anchor straps around stud leaving sufficient clearance between frame return and stud for inserting finished wall material (see Figure 26 and Figure 27).

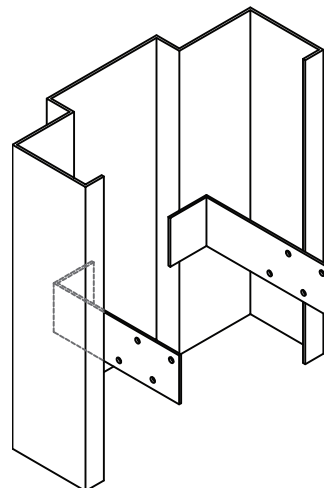

Figure 26 – Weld in strap anchors wood/steel studs

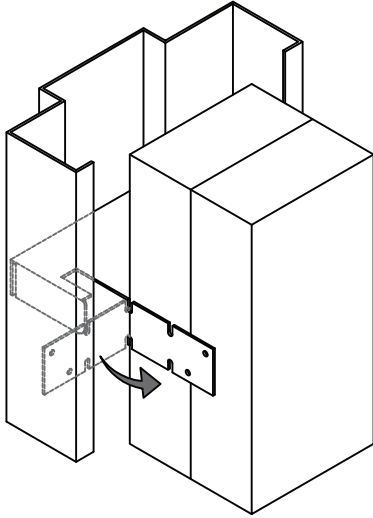

Figure 27 – Snap or weld in anchors wood/steel studs

10.6 Square and nail top anchor to stud on ONE JAMB ONLY. Check plumb and square and continue to nail balance of anchors to stud. Repeat for opposite jamb. For steel studs install screws from back of stud into Z anchor (see Figure 28).

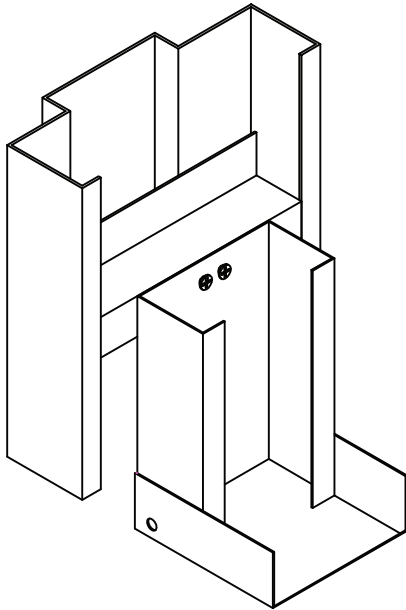

Figure 28 – Z Type weld in anchors steel studs

10.6.1 NOTE: At wrap-around installations in fire-rated walls, at least one layer of drywall on each side shall extend at least ½" (12.7 mm) into frame throat. See Section 12 for frame installations in butted or existing stud walls. See Figure 23-A, B and C.

11 Slip-on drywall

11.1 Prepare rough opening (see Figure 29) per frame manufacturer's recommendations.

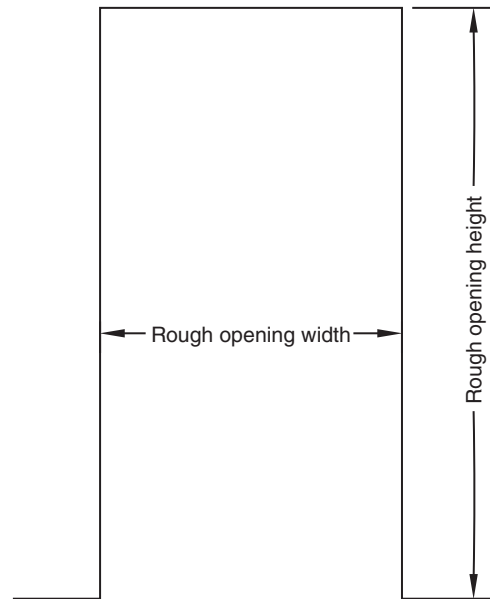

Figure 29 – Rough opening per manufacturer recommendations

11.1.1 Nesting or overlapping stud joints or other wall construction practices that will increase the overall wall thickness beyond the intended finished thickness are to be avoided.

11.2 Install base anchors if not factory welded to jamba or if frame faces are not prepared for base anchor screws.

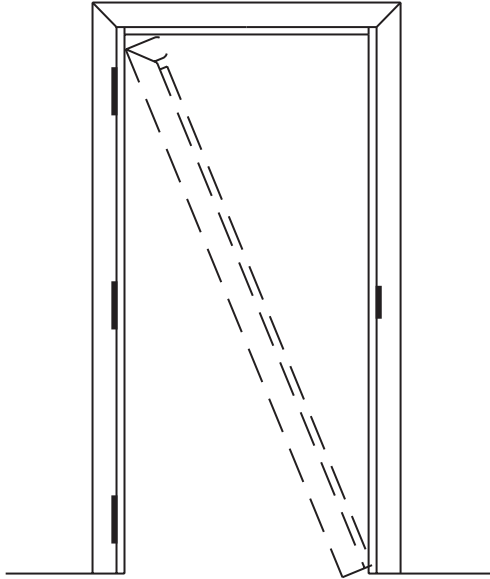

Figure 30 – Align corner gussets

11.3 Install jambs and header onto wall per manufacturer’s instructions, taking care to align corner gussets (if so equipped). See Figure 30.

11.4 Level and square frame (see Figure 31).

11.4.1 Install wood spreaders.

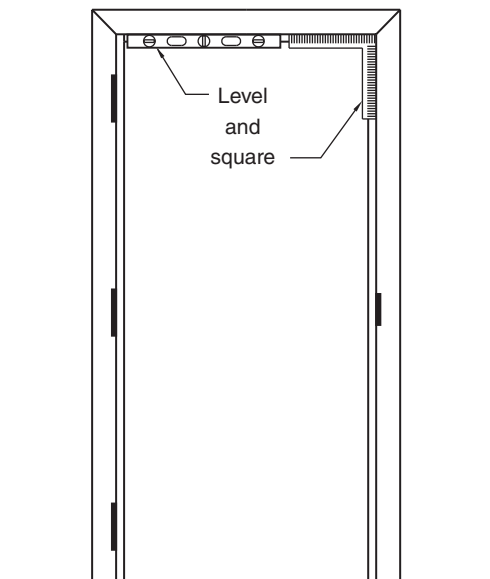

Figure 31 – Level and square frame

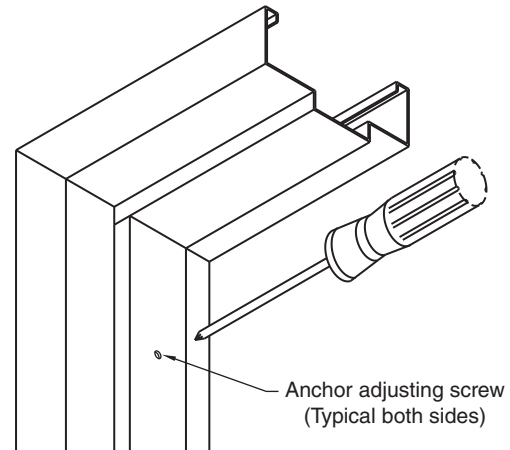

Figure 32 – Anchor adjusting screw

11.5 Turn adjusting screws hand tight (DO NOT USE SCREW GUN) until compression anchor contacts jamb studs (see Figure 32).

11.6 Re-check level and square. Adjust using anchor screws as needed.

11.7 Fasten base anchors to wall stud (see Figure 33) or fasten to wall studs through prepared holes in face of jambs at bottom.

12 Butted or Existing Steel or Wood Stud Wall Construction

12.1 Historically, frames installed in fire-rated stud walls required frames to wrap around the wall and drywall must extend at least ½” (12.7 mm) into frame throat. Fire testing has confirmed that fire door frames will perform satisfactorily to the acceptance criteria of UL 10C under positive pressure when butted to new or existing stud and drywall construction (see Figure 34 and Figure 35).

12.1.1 This installation has been incorporated into NFPA 80 as Figure A.6.3.1.3(a) and A.6.3.1.3(b).

12.1.2 Applicable Building Codes and individual manufacturers’ product listings shall be consulted when these butted frames are used in fire-rated walls.

12.1.3 This installation process DOES NOT apply to Slip-on Drywall frames in Section 11.

12.1.4 Listed fill, void or cavity material shall be used at the junction of frame faces and

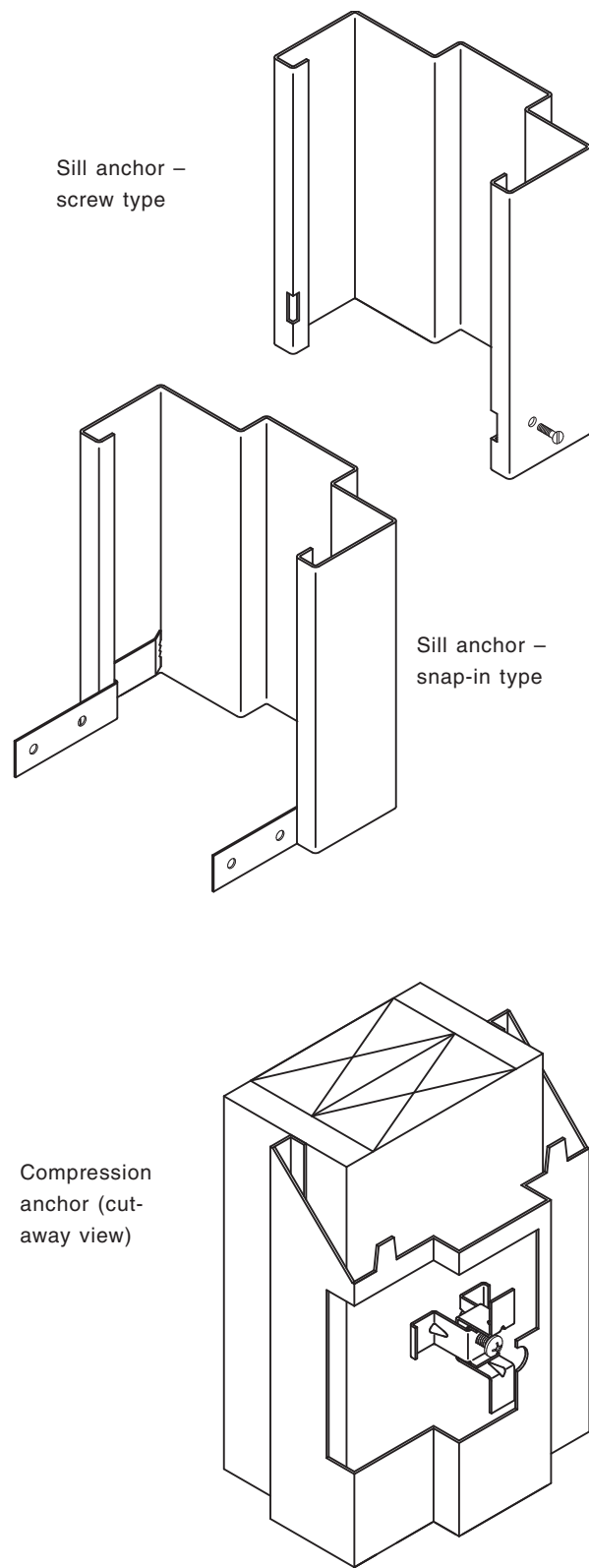

returns with the drywall surface. The bead of fill, void or cavity material shall be no wider than 1/2" (12.7 mm).

12.2 Assemble knock down frames per manufacturer's instructions.

12.3 Anchors are typically welded to frames and will either be a sleeve aligned with a countersunk hole or a plate between returns with an access hole and plug.

12.4 Assure that rough opening is plumb, square, and properly sized to fit overall frame dimensions and expansion capability of intumescent caulk or sealant. (See SDI 127F for further information).

12.5 Using a "stud finder" or similar tool, assure that studs will align with frame mounting screws.

12.6 Slide frame into wall opening; install wood spreaders at the floor and mid-height of opening.

12.7 Use tapered shims between anchors and wall and spreaders to maintain squareness and alignment of frame and to maintain door opening. Make sure that shims will not interrupt the sealant.

12.8 Insert 1/4" (6.4 mm) sheet metal screws of suitable length to engage studs through countersink or access hole in frame (see Figure 34 and Figure 35) and tighten securely. Check for frame alignment periodically. (Frame profiles shown are for general details only. Anchors and profiles may vary).

12.9 Insert plugs to cover access holes if so equipped.

12.10 Install listed intumescent caulk or sealant around perimeter of frame, making sure to cover any gaps caused by irregularities in walls.

Figure 33 – Fasten base anchors to wall stud

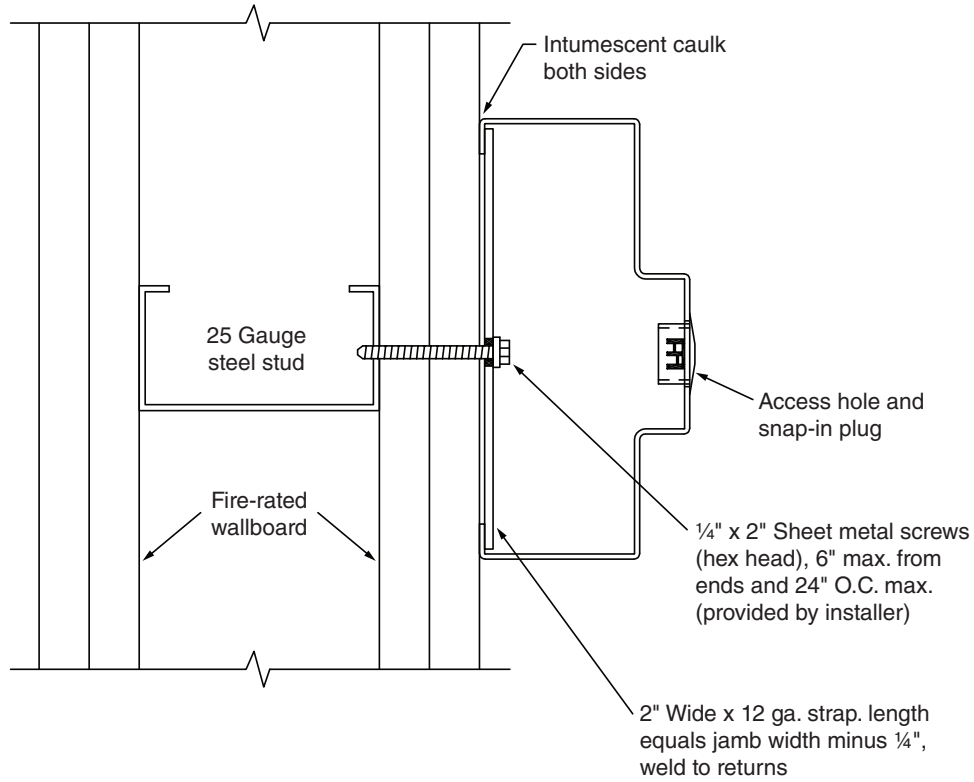

Figure 34 – Hole plug mount

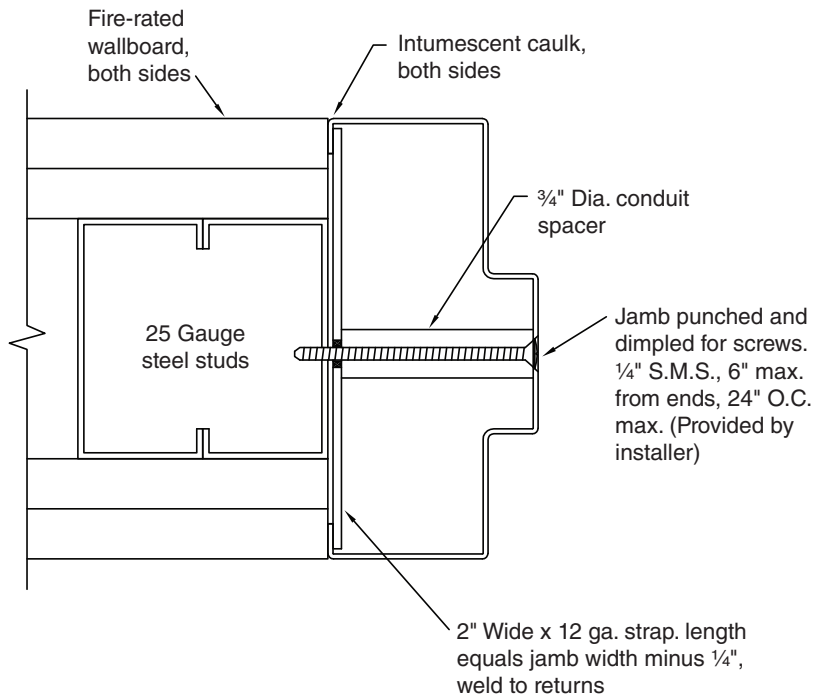

Figure 35 – Countersink mount