

Motic®

30⁺
YEARS



PA53 BIO / PA53 FS6

Microscopy Solutions for Clinical
and Life Science Applications

PA53 Series – Upright Biological Laboratory Microscopes

The PA53 upright biological laboratory microscope series is designed with the user in mind. In keeping with Motic Scientific's mission statement of providing technologies for people at affordable prices, we are proud to offer our new entry level high-end microscope series for clinical and life science applications with an impressively high price to performance ratio. Our PA53 BIO and PA53 FS6 models have an ergonomic design helping to reduce user fatigue during extended periods of use and also feature intuitive control layout for optimized and efficient workflow.

The modularity of the PA53 biological series microscopes offers you flexibility in choosing a cost-efficient or advanced configuration depending on your needs. It also allows the ability to upgrade your configuration should your daily workflow change or require different illumination techniques. Whether you are observing HE stained tissue in brightfield, need to study endothelial cells under phase contrast, diagnose a potential case of gout with polarization or perform advanced FISH/HER2 analysis with bright fluorescence imaging, the PA53 biological series has you covered---and won't break the bank.



PA53 BIO

Featuring Intelligent & Convenient Functionality Increase Your Work Efficiency and Comfort

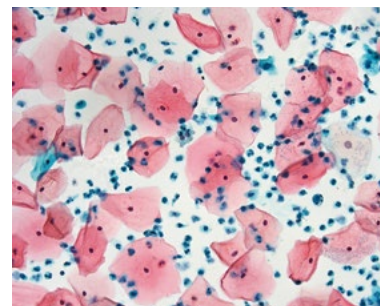

Cytology

Transmitted, Full Kohler 100W Halogen Illumination

Our standard PA53 BIO and PA53 FS6 configurations are equipped with transmitted, full Kohler 100W halogen illumination. Intelligent heat-reduction engineering ensures you can use our 100W halogen illumination for long periods without worrying about injury due to overheating. Our 100W halogen bulbs also feature a lifespan 5 times higher than traditional 30W halogen bulbs, meaning more time for your lab work.

Comfortable Viewing

In order to reduce operator eyestrain, our standard PA53 BIO and PA53 FS6 configurations are equipped with super wide-field FN23, diopter adjustable eyepieces. The 30-degree, Siedentopf type observation tube offer light distribution of 100:0, 20:80, and 0:100 and ensures a comfortable viewing angle during extended use. Furthermore, the prismatic lenses used provide strong chromatic aberration correction, ensuring you are viewing your samples in true-to-life colors.

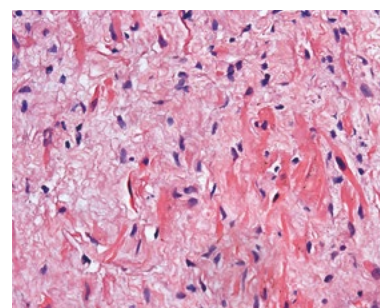

Haematoxylin and Eosin Stain (HE)

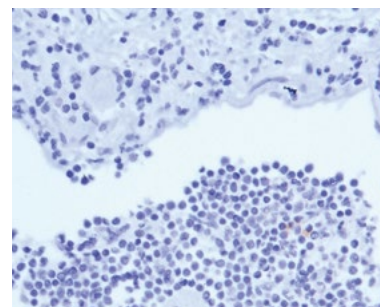

Immunohistochemistry (IHC)

Convenient, Multifunctional Illumination Control Knob

With your workflow and ease of use in mind, our PA53 BIO and PA53 FS6 models come standard with multifunctional illumination control knobs. Control illumination intensity or switch between reflected and transmitted light with ease.

Environmentally Friendly ECO Function

An automatic power saving mode is engaged whenever an operator leaves temporarily. This power saving mode is enabled to protect your samples from the heat of the illuminator. ECO mode also results in energy savings which extend the lifetime of the lamp and reduce overall operational costs.

Consistent, Even Illumination with IL Function

Working efficiency is further increased by providing an optimized consistent, even brightness in illumination with the IL function. With the IL function engaged, the brightness level will be maintained even if the observation magnification is changed during observation.

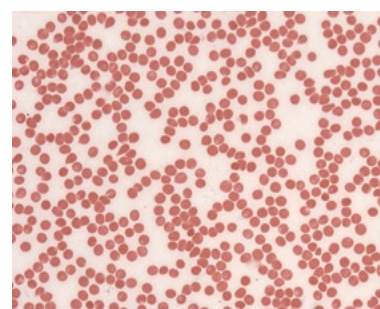

Hematology

PA53 FS6 – Upright Fluorescence Microscopes

The PA53 FS6 offers a reflected fluorescence illumination system with our high-powered LUMOS LED or traditional mercury-arc lamp set-up. Up to six filter cubes can be inserted into the coded fluorescence turret to ensure optimal multi-color fluorescence observation. Our standard configuration PA53 FS6 features mounted, high quality DAPI, FITC, and TRITC filter cubes in addition to 2 empty filter cubes which can be mounted by the user depending on their specific research or application needs. We also offer a mounted filter cube for FISH analysis which is recommended to be used with our long lifecycle (20,000 + hours) LUMOS LED.

Our expertly designed, carefully in-house crafted, high-performance Plan UC Fluor objectives provide an ultra-flat, high-contrast image perfect for use with the LUMOS FL LED Lamp to obtain high quality bright fluorescence imaging in the UV-Visible light range.



PA53 FS6

From Simple Measurements to Complicated Analyses Our Superior Optical Performance Fulfills Your Needs

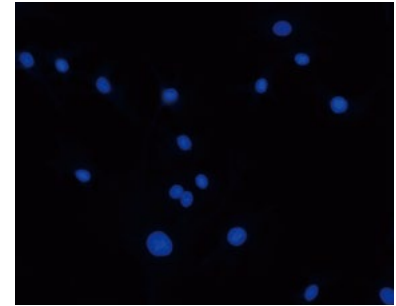
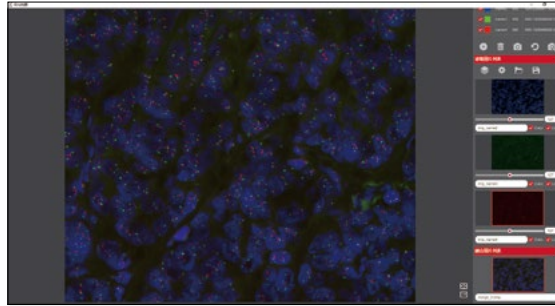

DAPI
Exciter filter (wave length) : D350/50x nm
Beam splitter filter (wave length) : 400DCLP nm
Emitter filter (wave length) : D460/50m nm

Fluorescence Module

The coded fluorescence turret automatically remembers the fluorescence channel and each channels brightness. This avoids the issue of stray light and saves you from having to purchase expensive OD6 or OD8 filters to increase fluorescence performance.

Motic Fluorescence Imaging Software

Our Motic Fluorescence Imaging Software plug-in for Motic Images Plus 3.0 is included with all PA53 FS6 purchases. It was developed in-house and offers a professional fluorescence digital image processing solution for multi-channel imaging. This software supports up to four channel imaging which can then be merged to meet FISH and other fluorescence imaging analysis applications.

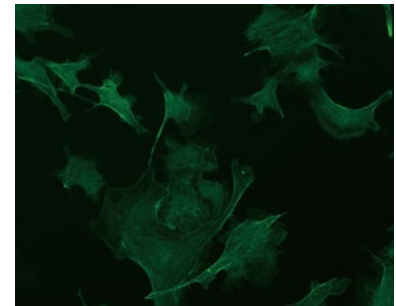

FITC
Exciter filter (wave length) : D480/30x nm
Beam splitter filter (wave length) : 505DCLP nm
Emitter filter (wave length) : D535/40m nm

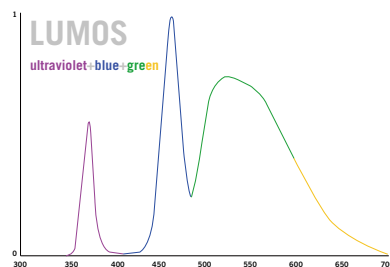

LUMOS FL : High-Powered UV-BG Fluorescence LED Lamp

- ◆ Features apochromatic design.
- ◆ Compared to the lifespan of only 200 hours and the high cost of mercury-arc lamps, the LUMOS FL provides over 20,000 hours of use.
- ◆ No light toxicity like traditional mercury-arc lamps which can damage samples with infrared light heat toxicity.
- ◆ Instant On/Off: Unlike traditional mercury-arc lamps which take up to 20 minutes to reach optimal brightness levels when turned on, the LUMOS FL is ready for use at the flip of a switch.
- ◆ Does not pose toxic gas danger to users.
- ◆ Avoids stray light interference during observation, helping to avoid errors in user interpretation of images.
- ◆ Individually controls each LED channel and eliminates need for multiple filters therefore reducing filter cube expense.
- ◆ Features a broad spectrum spread which can satisfy multiple user applications.

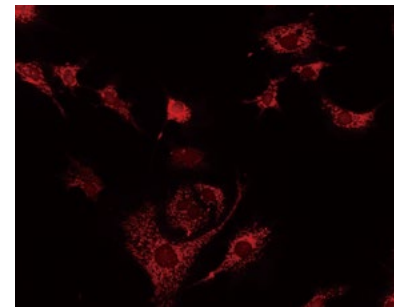

TRITC
Exciter filter (wave length) : D540/25x nm
Beam splitter filter (wave length) : 565DCLP nm
Emitter filter (wave length) : D605/55m nm

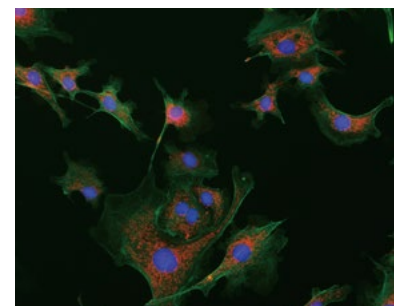

RGB Three channels Integration



High Performance sCMOS Technology

The new Moticam S line of cameras mark yet another milestone in Motic's digital microscopy expansion. By utilizing the latest sCMOS sensors coupled with our own PCB design and on-board image management systems, each Moticam S promises to deliver professional digital microscopy solutions at an affordable price. This new scientific grade Moticam line is designed and manufactured totally in-house under strict German quality guidelines. Whether for Clinical, Research or Industrial use, this new generation of Moticam has a model for even the most demanding users. The Moticam brand is recognized around the world as representing easy to use and adaptable attachable cameras for virtually any microscope. At Motic, we believe in making quality Digital Microscopy affordable for everyone and we know that you will enjoy this new line.

Key Features

- ◆ Super-fast frame rates with USB 3.1 data transfer.
- ◆ Offers resolution up to 12 MP.
- ◆ Rolling shutter or global shutter models depending on your specific application.
- ◆ Excellent true color reproduction.

MOTICAM S TECHNICAL SPECIFICATIONS

Moticam	S1	S3	S6	S12	MoticamProS5 Lite	MoticamProS5 Plus
Sensor Type	CMOS					
Sensor Size	1/3"	1/2.8"	1/1.8"	1/1.7"	2/3"	2/3"
Resolution	1.2M	3M	6M	12M	5M	5M
Imaging Area (Diagonal)	6.09mm	6.44mm	8.92mm	9.33mm	11.1mm	11.1mm
Pixel Size	3.75µm x 3.75µm	2.5µm x 2.5µm	2.4µm x 2.4µm	1.85µm x 1.85µm	3.45µm x 3.45µm	3.45µm x 3.45µm
Max. Frame Rate:	1280x960@120fps	2048x1536@60fps	3072x2048@30fps	4000x3000@25fps	2448x2048@35.7fps	2448x2048@68.3fps
	640x480@240fps	1920x1080@60fps	1536x1024@50fps	2048x1080@50fps	1224x1024@88.4fps	1224x1024@175.8fps
Scan Mode	Progressive					
Shutter Mode	Rolling Shutter	Rolling Shutter	Rolling Shutter	Rolling Shutter	Global Shutter	Global Shutter
Data Transfer	USB3.1					
Exposure Time	15us~2sec	21us~2sec	16us~2sec	22us~2sec	14us~2sec	7us~2sec
Sensitivity (G)	2350 mV @ 1/30 sec	600 mV @ 1/30 sec	425 mV @ 1/30 sec	280 mV @ 1/30 sec	1146 mV @ 1/30 sec	1146 mV @ 1/30 sec
Focusable Lens	12mm	12mm	16mm	16mm	16mm	16mm
Power consumption	less1.0W@ 5V(USB-supply)				less1.5W@ 5V(USB-supply)	
Lens Mount	CS-Mount					
Support Device	TWAIN, SDK and DirectShow Driver					
Supported OS (Recommended)	Higher than Microsoft Windows7/8/10, MAC OSX10.9 and Linux					
Minimum Computer Requirements (Recommended)	2GHz Dualcore, RAM memory 2GB and Video Memory Min 512MB					
Operating Temperature	From -10 to + 60 degree celsius non condensing					
Package Includes	CS Ring Adaptor, Calibration Slide, USB3.1 cable, Image Plus 3.0 for PC / OSX / Linux(Accessories Package) Focusable Lens, 30mm and 38mm Eyepiece Adaptor, Macro Tube and Macro Tube Calibration dot					

SYSTEM OVERVIEW

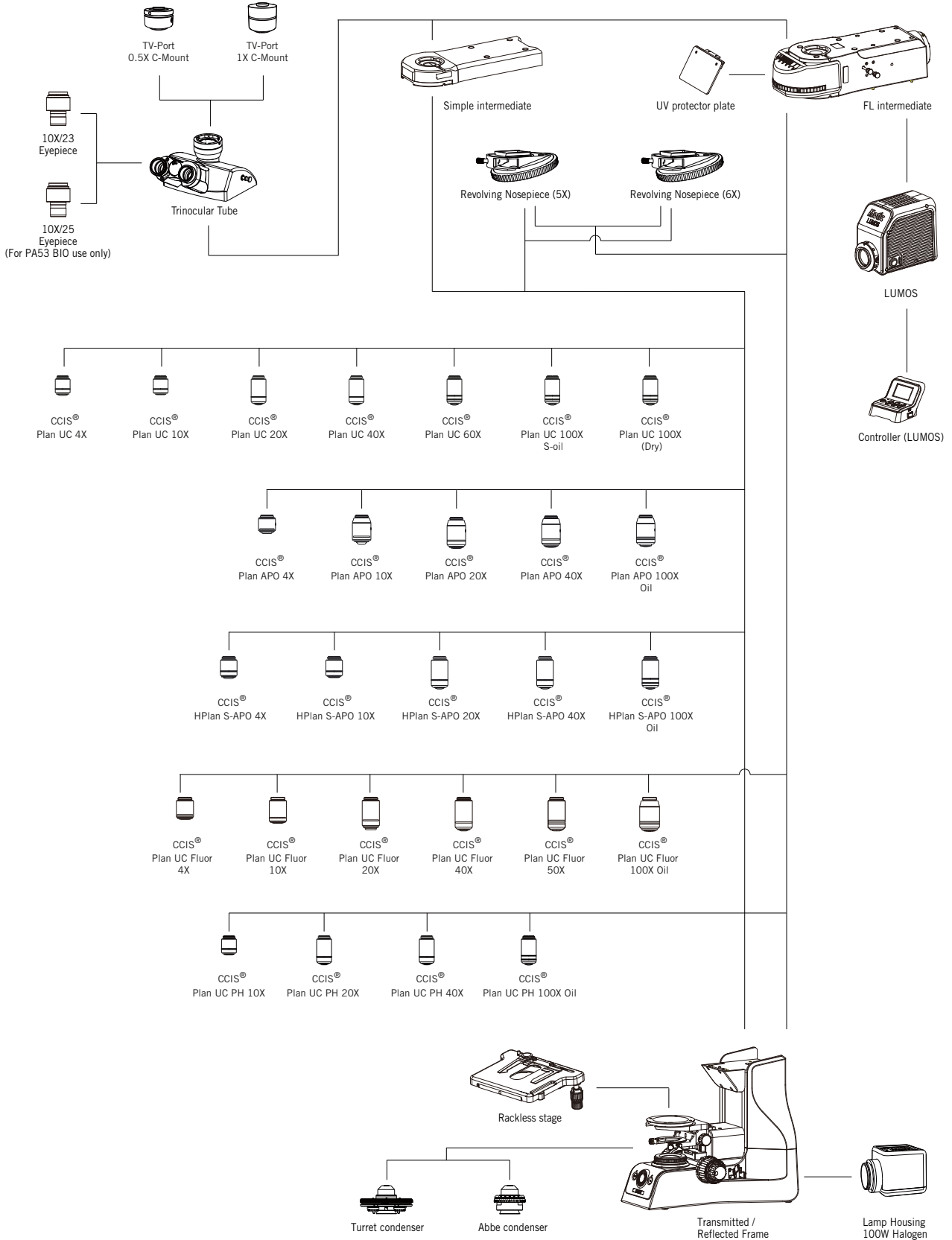

SPECIFICATIONS

Model	PA53 BIO	PA53 FS6
Optical System	Scalable Infinity-Corrected Optical System(CCIS®)	
Illumination	Transmitted Illumination System	Transmitted / Reflected Fs Illumination System
Transmitted illumination	Kohler illumination 100W long life halogen lamp	
Reflected Flour Illumination	/	High-power LED Flour Light source
Observation Tube	30°Trinocular (100:0,20:80,0:100)	
Eyepieces	Wide-Field(FN23) Eyepiece 10X/23mm, Diopter adjustable	
	Wide-Field(FN25) Eyepiece 10X/25mm, Diopter adjustable	/
Nosepiece	Coded Quintuple(5) revolving nosepiece	
Recommended Objectives	Plan UC Achromat Series Plan UC 4X/0.1, W.D=30.5mm,CG=0.17 Plan UC 10X/0.25, W.D=17.4mm,CG=0.17 Plan UC 20X/0.45,W.D=0.8mm,CG=0.17 (Optional) Plan UC 40X/0.65,W.D=0.6mm,CG=0.17 Plan UC 60X/0.8,W.D=0.35mm,CG=0.17 (Optional) Plan UC 100X/1.25 Oil,W.D=0.16mm,CG=0.17 Plan UC 100X/0.8,W.D=2mm,CG=0.17	Plan UC Fluor Series Plan UC Fluor 4X/0.13,W.D=17.3mm,CG=0.17 Plan UC Fluor 10X/0.3,W.D=11.7mm,CG=0.17 Plan UC Fluor 20X/0.5,W.D=2.2mm,CG=0.17 Plan UC Fluor 40X/0.75,W.D=0.7mm,CG=0.17 Plan UC Fluor 100X/1.3 oil,W.D=0.1mm,CG=0.17
Plan APO Series	Plan APO 4X/0.15 W.D.=20mm,CG=0.17 Plan APO 10X/0.35 W.D.=4.2mm,CG=0.17 Plan APO 20X/0.75 W.D.=0.55mm,CG=0.17 Plan APO 40X/0.95 W.D.=0.18mm,CG=0.17 Plan APO 100X/1.3 oil. W.D.=0.25mm,CG=0.17	/
HPlan S-APO Series	HPlan S-APO 4X/0.13,W.D=17.3mm,CG=0.17 HPlan S-APO 10X/0.3,W.D=11.7mm,CG=0.17 HPlan S-APO 20X/0.5,W.D=2.2mm,CG=0.17 HPlan S-APO 40X/0.75,W.D=0.7mm,CG=0.17 HPlan S-APO 100X/1.3 oil,W.D=0.1mm,CG=0.17	/
Plan UC Phase Contract Series	Plan UC PH 10X/0.25, W.D=17.4mm,CG=0.17,ph1 Plan UC PH 20X/0.45,W.D=0.8mm,CG=0.17,ph2 Plan UC PH 40X/0.65,W.D=0.6mm,CG=0.17,ph2 Plan UC PH 100X/1.25 Oil,W.D=0.16mm,CG=0.17,ph3	
Focusing Mechanism	Stage Z range: 29.5 mm, Coarse and Fine focusing knob Coarse focusing : 17.7mm/turn; fine focusing: 0.1/turn, Upper limit stopper, Torque adjustment ring	
Condenser	Abbe condenser	
Stage	Rackless stage	
Filter Cubes	/	DAPI/Hoechst/AlexaFluor 350 EGFP/FITC/Cy2/AlexaFluor 488 TRITC/Cy3/TagRFP/AlexaFluor 546 DAPI/Green/Orange #1 FISH (Multiple filter cube options available on request consult with your Motic sales representative)
Software	Motic Images Plus 3.0 (Best paired with Moticam S line cameras)	
	/	Motic Images Plus 3.0 FL channel merge plug-in

DIMENSIONS

PA53 BIO

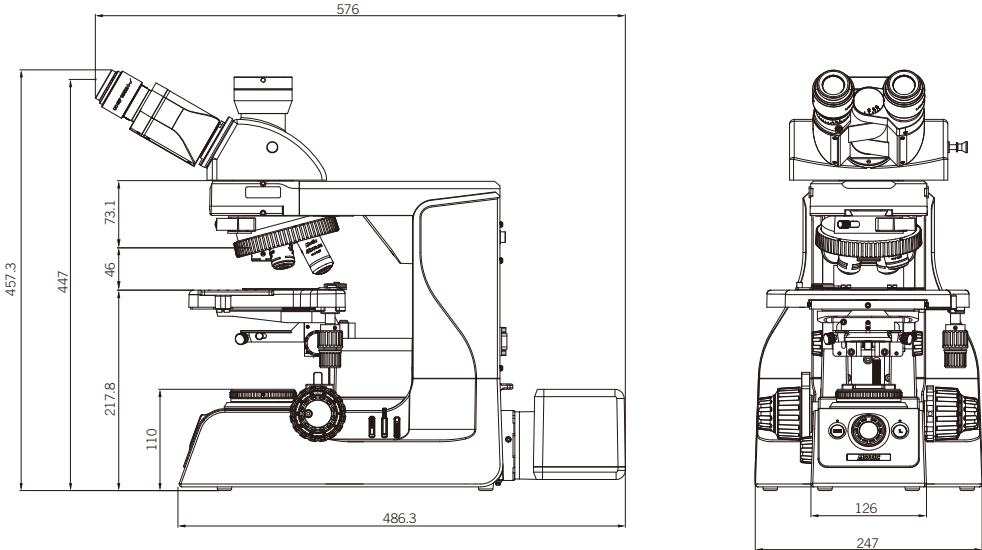

PA53 FS6

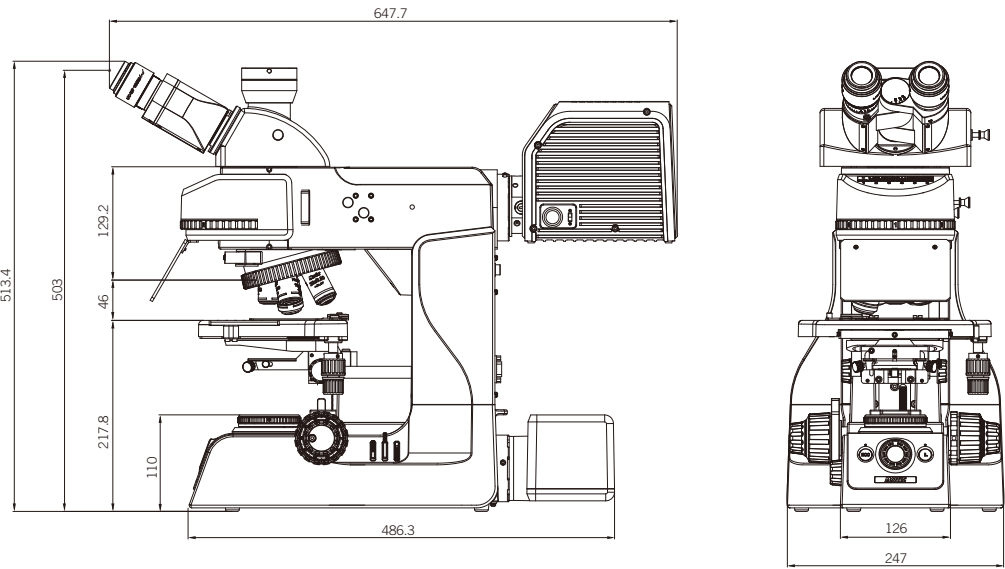

Motic®

Canada | China | Germany | Spain | USA



www.motic.com

EN | ES | FR | DE | IT | PT

Motic Instruments (Canada)

130 - 4611 Viking Way, Richmond, BC V6V 2K9 Canada
Tel: 1-877-977 4717 | Fax: 1-604-303 9043

Motic Deutschland GmbH (Germany)

Christian-Kremp-Strasse 11, D-35578 Wetzlar, Germany
Tel: 49-6441-210 010 Fax: 49-6441-210 0122

Motic Hong Kong Limited (Hong Kong)

Unit 2002, L20, Tower Two, Enterprise Square Five, 38 Wang Chiu Road,
Kowloon Bay, Kowloon, Hong Kong
Tel: 852-2837 0888 | Fax: 852-2882 2792

Motic Europe (Spain)

C. Les Corts 12, Pol. Ind. Les Corts. 08349 Cabrera de Mar, Barcelona, Spain
Tel: 34-93-756 6286 | Fax: 34-93-756 6287

*CCIS® is a trademark of Motic Incorporation Ltd.

Motic Incorporation Limited Copyright © 2002-2020. All Rights Reserved.

Design Change: The manufacturer reserves the right to make changes in instrument design in accordance with scientific and mechanical progress, without notice and without obligation.

Designed at Motic Scientific in Xiamen

Updated: 2021.01.06



Official Distributor: