

# UNIVERSAL TRASH CAN DUMPER - TCD-U-48-DC

APPROX WEIGHT: 713.28 lbs.  
DOES NOT INCLUDE WEIGHT OF POWER OR PACKAGING!!!

\*\*\*ANY ADDITIONS, DELETIONS, OR OMISSIONS MUST BE CORRECTED ON THIS DRAWING AS THIS DRAWING WILL BE CONSIDERED ALL INCLUSIVE\*\*\*

ALL GRAPHICS PROVIDED ARE FOR REFERENCE ONLY. IF CERTAIN DIMENSIONS ARE CRITICAL PLEASE VERIFY THOSE DIMENSIONS WITH YOUR SALESPERSON

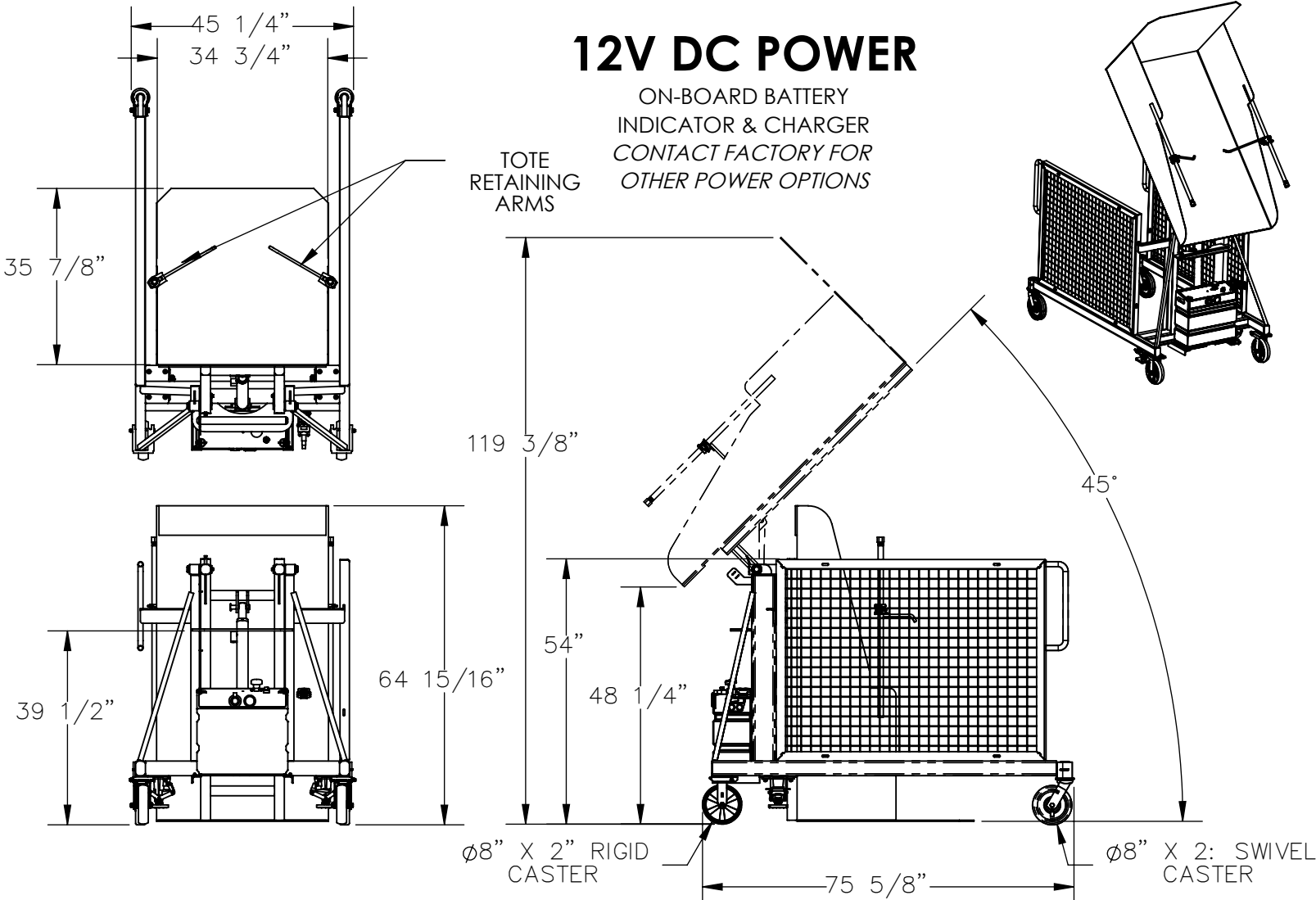

## STANDARD FEATURES

- MODEL NUMBER: TCD-U-48-DC
- USABLE CHUTE WIDTH: 34 3/4"
- USABLE CHUTE LENGTH: 35 7/8"
- OVERALL LENGTH: 75 5/8"
- OVERALL WIDTH: 45 1/4"
- OVERALL HEIGHT: 64 15/16"
- OVERALL ROTATED HEIGHT: 119 3/8"
- MAXIMUM ROTATED ANGLE: 45°
- DUMP HEIGHT: 48 1/4"
- WORKS WITH TRASH CANS OF
  - 17 1/2" TO 34" WIDTH
  - 20 1/2" TO 35 7/8" LENGTH
  - 27" TO 50" HEIGHT
- UNIFORM CAPACITY IS 400 LBS
- CASTERS:
  - FRONT: 8" X 2" GFN SWIVEL
  - REAR: 8" X 2" GFN RIGID
- TWO ADJUSTABLE FLOOR LOCKS
- INTERNAL POWER UNIT: 12V DC  
WITH ON-BOARD CHARGER
- HANDHELD PUSH BUTTON CONTROL,  
W/8ft. EXTENDED COIL CORD

FRAME: DURABLE LIQUID PAINT BLUE FINISH  
CHUTE: DURABLE BAKED IN POWDER COATED  
YELLOW FINISH

## SPECIAL FEATURES

NONE

DIMENSION TOLERANCE ± 1/4"

<b>A P P R O V A L</b>	I, THE UNDERSIGNED, AGREE THAT THE PRODUCT AS REPRESENTED SATISFIES DESIGN AND DIMENSION REQUIREMENTS. I ALSO ACKNOWLEDGE MY DUTY TO CONFIRM PRODUCT AND INSTALLATION COMPLIANCE WITH ALL APPLICABLE FEDERAL, STATE AND LOCAL REGULATIONS AND STANDARDS.	
	<b>UNITS REQUIRING APPROVAL DRAWINGS OR MODIFIED ARE NON-RETURNABLE</b>	
[ ] As drawn      [ ] As marked		
Signed: _____ Date: _____		
Printed Name: _____		
<i>LEAD TIME WILL START UPON RECEIPT OF SIGNED APPROVAL DRAWING</i>		

DISTRIBUTOR'S NAME: <b>VESTIL MANUFACTURING</b>		P.O.# X
DRAWN BY: <b>SJA</b>		W.O.# X
DATE: <b>7/23/2016</b>		SALES: X
REFERENCE: X		SCALE: 1:32
QUOTED LEAD TIME: X		QUOTE # X
		FILE NAME: 34-007-023