

QDD4-400GB-SR4-BD-AR-AO

Arista Networks® Compatible TAA 400GBase-BX SR4.2 PAM4 QSFP-DD Transceiver (MMF, 850nm to 902nm, 100m, MPO-12, DOM, CMIS 4.0)

Features

- 8x50 Gbps MMF optical interface
- 850nm/908nm VCSEL 850nm/908nm PD Array Technology
- Supports 4x100G breakout function
- Multi-mode fiber
- CMIS V4.0 compliance
- MPO-12 connector
- Hot Pluggable
- Commercial Temperature 0 to 70 Celsius
- RoHS Compliant and lead-free
- Excellent ESD Protection



Applications

- 400GBase Ethernet
- Access and Enterprise

Product Description

This Arista Networks® QSFP-DD transceiver provides 400GBase-BX SR4.2 throughput up to 100m over multi-mode fiber (MMF) using a wavelength of 850nm to 902nm via an MPO-12 connector. It is guaranteed to be 100% compatible with the equivalent Arista Networks® transceiver. This easy to install, hot swappable transceiver has been programmed, uniquely serialized and data-traffic and application tested to ensure that it will initialize and perform identically. Digital optical monitoring (DOM) support is also present to allow access to real-time operating parameters. This transceiver is Trade Agreements Act (TAA) compliant. We stand behind the quality of our products and proudly offer a limited lifetime warranty.

AddOn's transceivers are RoHS compliant and lead-free.

TAA refers to the Trade Agreements Act (19 U.S.C. & 2501-2581), which is intended to foster fair and open international trade. TAA requires that the U.S. Government may acquire only "U.S. – made or designated country end products."



Absolute Maximum Ratings

Parameter	Symbol	Min.	Typ.	Max.	Unit	Notes
Maximum Supply Voltage	V _{cc}	-0.5		3.6	V	1
Storage Temperature	T _{stg}	-40		85	°C	1
Storage Relative Humidity	RH	0		95	%	1, 2
Operating Case Temperature	T _c	0	25	70	°C	
Operating Relative Humidity	RH	0		85	%	1, 2
Signaling Speed Per Channel	S		26.56		GB	

Notes:

1. Exceeding the Absolute Maximum Ratings may cause irreversible damage to the device. The device is not intended to be operated under the condition of simultaneous Absolute Maximum Ratings, a condition which may cause irreversible damage to the device.
2. Non-condensing condition.

Electrical Characteristics

Parameter	Symbol	Min.	Typ.	Max.	Unit	Notes
Module Supply Voltage	V _{cc}	3.14	3.3	3.46	V	
Power Consumption	P		11		W	
Module Supply Current	I _n		3500		mA	
Transmitter						
Tx_Data Differential Input Voltage	V _{IN}			900	mV	
Tx_Data Differential Input Impedance	Z _{IN}		100		Ω	
Receiver						
Rx_Data Differential Output Voltage	V _{OUT}			900	mV	
Rx_Data Differential Output Impedance	Z _{OUT}		100		Ω	

Optical Characteristics

Parameter	Symbol	Min.	Typ.	Max.	Unit	Notes
Transmitter						
Signaling Rate Per Lane	SR		26.56		GBd	
Signaling Speed Accuracy	SSA	-100		100	ppm	
Modulation Format		PAM4				
Average Launch Power Per Lane	POUT	-6.5		4	dBm	1
Outer Optical Modulation Amplitude Per Lane	OMAouter	-4.5		3	dBm	
Optical Output with Tx Off	POFF			-30	dBm	
Extinction Ratio	ER	3			dB	
$\lambda 1$ Center Wavelength (Range)	λ	840		868	nm	2
$\lambda 2$ Center Wavelength (Range)	λ	900		918	nm	3
RMS Spectral Width ($\lambda 1$)	$\Delta\lambda$			0.65	nm	
RMS Spectral Width ($\lambda 2$)	$\Delta\lambda$			0.65	nm	
Transmitter and Dispersion Eye Closure (TDECQ) Per Lane	TDECQ			4.5	dB	
Launch Power in OMAouter Minus TDECQ Per Lane (Minimum)		-5.9			dB	
Optical Return Loss Tolerance (Maximum)	ORLT			12	dB	
Receiver						
Signaling Rate Per Lane	SR		26.56		GBd	
Signaling Speed Accuracy		-100		100	ppm	
Modulation Format		PAM4				
Average Power at Receive Input Per Lane	PIN	-8.5		4	dBm	
Receive Power (OMAouter) Per Lane (Maximum)				3	dBm	
Receiver Sensitivity (OMAouter) Per Lane	S			Max. (-6.6, SECQ-8)	dBm	4
$\lambda 1$ Center Wavelength (Range)	λ	840		868	nm	2
$\lambda 2$ Center Wavelength (Range)	λ	900		918	nm	3
Rx_LOS - Assert	LOSA	-24.6			dBm	
Rx_LOS - De-Assert	LOSD			-8.6	dBm	
Rx_LOS - Hysteresis	LOSH	0.5			dB	

Notes:

1. Average Optical Output.
2. TxRx pair type TR.
3. TxRx pair type RT.
4. Sensitivity where the BER=2.4E⁻⁴ measured with a PRBS 31Q test pattern @26.56GBaud.

Pin Descriptions

Pin	Logic	Symbol	Name/Descriptions
1		GND	Module Ground.
2	CML-I	Tx2-	Transmitter Inverted Data Input.
3	CML-I	Tx2+	Transmitter Non-Inverted Data Input.
4		GND	Module Ground.
5	CML-I	Tx4-	Transmitter Inverted Data Input.
6	CML-I	Tx4+	Transmitter Non-Inverted Data Input.
7		GND	Module Ground.
8	LVTTTL-I	ModSelL	Module Select.
9	LVTTTL-I	ResetL	Module Reset.
10		VccRx	+3.3V Power Supply Receiver.
11	LVC MOS-I/O	SCL	2-Wire Serial Interface Clock.
12	LVC MOS-I/O	SDA	2-Wire Serial Interface Data.
13		GND	Module Ground.
14	CML-O	Rx3+	Receiver Non-Inverted Data Output.
15	CML-O	Rx3-	Receiver Inverted Data Output.
16		GND	Module Ground.
17	CML-O	Rx1+	Receiver Non-Inverted Data Output.
18	CML-O	Rx1-	Receiver Inverted Data Output.
19		GND	Module Ground.
20		GND	Module Ground.
21	CML-O	Rx2-	Receiver Inverted Data Output.
22	CML-O	Rx2+	Receiver Non-Inverted Data Output.
23		GND	Module Ground.
24	CML-O	Rx4-	Receiver Inverted Data Output.
25	CML-O	Rx4+	Receiver Non-Inverted Data Output.
26		GND	Module Ground.
27	LVTTTL-O	ModPrsL	Module Present.
28	LVTTTL-O	IntL	Interrupt.
29		VccTx	+3.3V Power Supply Transmitter.
30		Vcc1	+3.3V Power Supply.
31	LVTTTL-I	InitMode	Initialization Mode.
32		GND	Module Ground.
33	CML-I	Tx3+	Transmitter Non-Inverted Data Input.
34	CML-I	Tx3-	Transmitter Inverted Data Input.
35		GND	Module Ground.
36	CML-I	Tx1+	Transmitter Non-Inverted Data Input.
37	CML-I	Tx1-	Transmitter Inverted Data Input.
38		GND	Module Ground.
39		GND	Module Ground.

40	CML-I	Tx6-	Transmitter Inverted Data Input.
41	CML-I	Tx6+	Transmitter Non-Inverted Data Input.
42		GND	Module Ground.
43	CML-I	Tx8-	Transmitter Inverted Data Input.
44	CML-I	Tx8+	Transmitter Non-Inverted Data Input.
45		GND	Module Ground.
46		Reserved	
47		VS1	Module Vendor-Specific 1.
48		VccRx1	+3.3V Power Supply.
49		VS2	Module Vendor-Specific 2.
50		VS3	Module Vendor-Specific 3.
51		GND	Module Ground.
52	CML-O	Rx7+	Receiver Non-Inverted Data Output.
53	CML-O	Rx7-	Receiver Inverted Data Output.
54		GND	Module Ground.
55	CML-O	Rx5+	Receiver Non-Inverted Data Output.
56	CML-O	Rx5-	Receiver Inverted Data Output.
57		GND	Module Ground.
58		GND	Module Ground.
59	CML-O	Rx6-	Receiver Inverted Data Output.
60	CML-O	Rx6+	Receiver Non-Inverted Data Output.
61		GND	Module Ground.
62	CML-O	Rx8-	Receiver Inverted Data Output.
63	CML-O	Rx8+	Receiver Non-Inverted Data Output.
64		GND	Module Ground.
65		NC	Not Connected.
66		Reserved	
67		VccTx1	+3.3V Power Supply.
68		Vcc2	+3.3V Power Supply.
69		Reserved	
70		GND	Module Ground.
71	CML-I	Tx7+	Transmitter Non-Inverted Data Input.
72	CML-I	Tx7-	Transmitter Inverted Data Input.
73		GND	Module Ground.
74	CML-I	Tx5+	Transmitter Non-Inverted Data Input.
75	CML-I	Tx5-	Transmitter Inverted Data Input.
76		GND	Module Ground.

Electrical Pin-Out Details

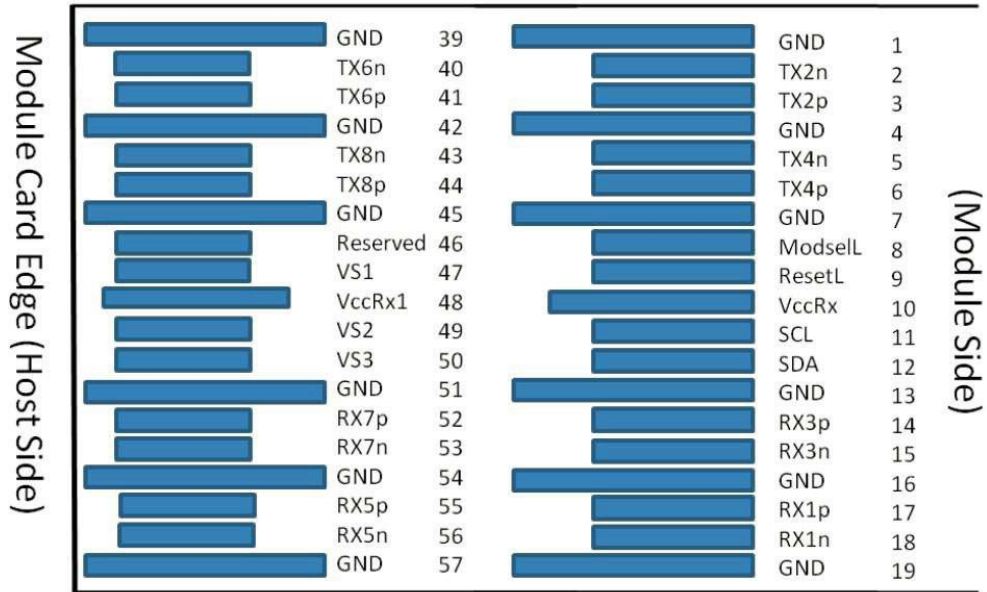

Bottom side viewed from bottom

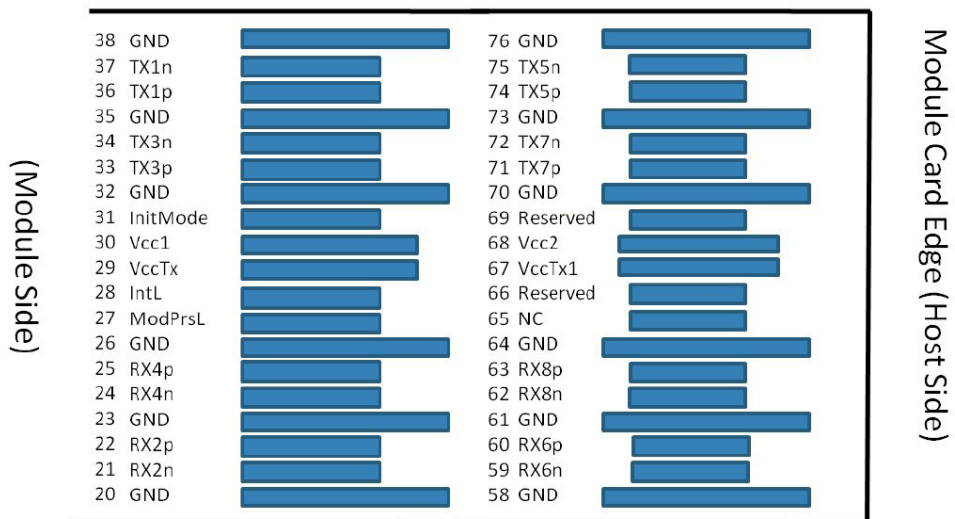

Top side viewed from top

Transceiver Block Diagram

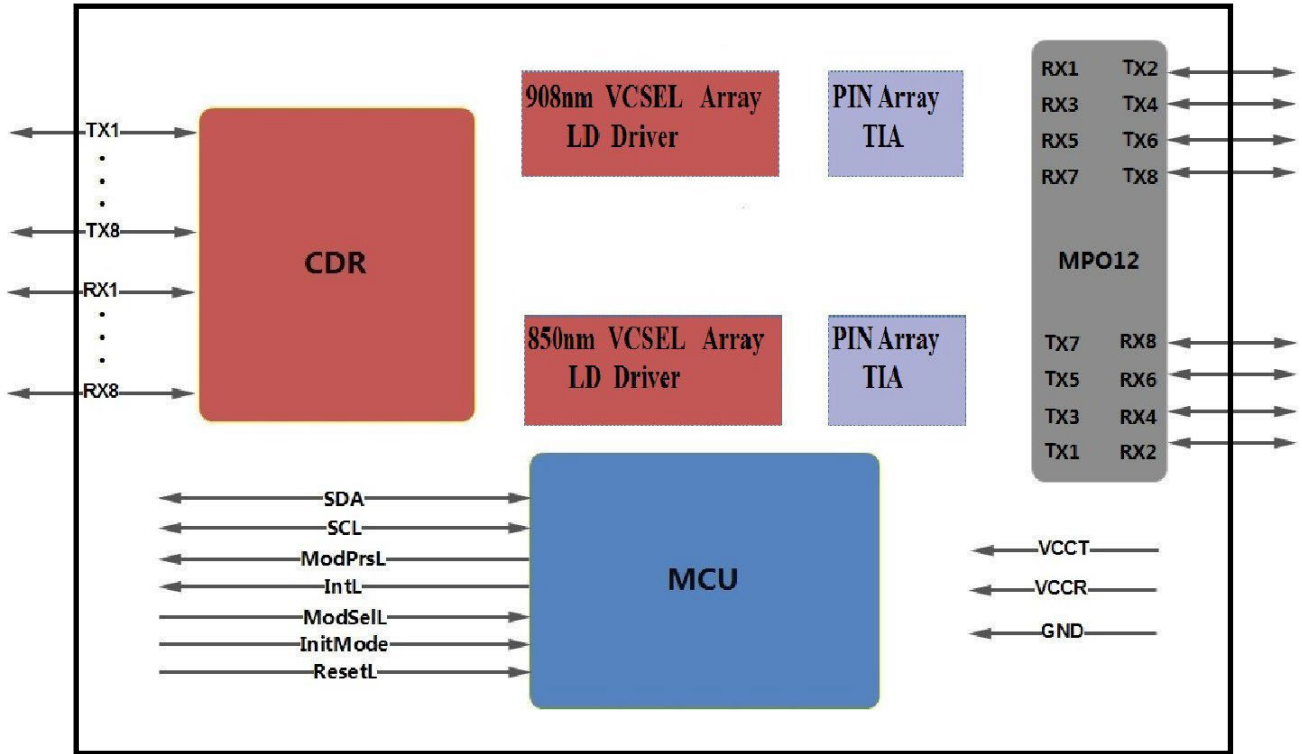

Electrical Interface

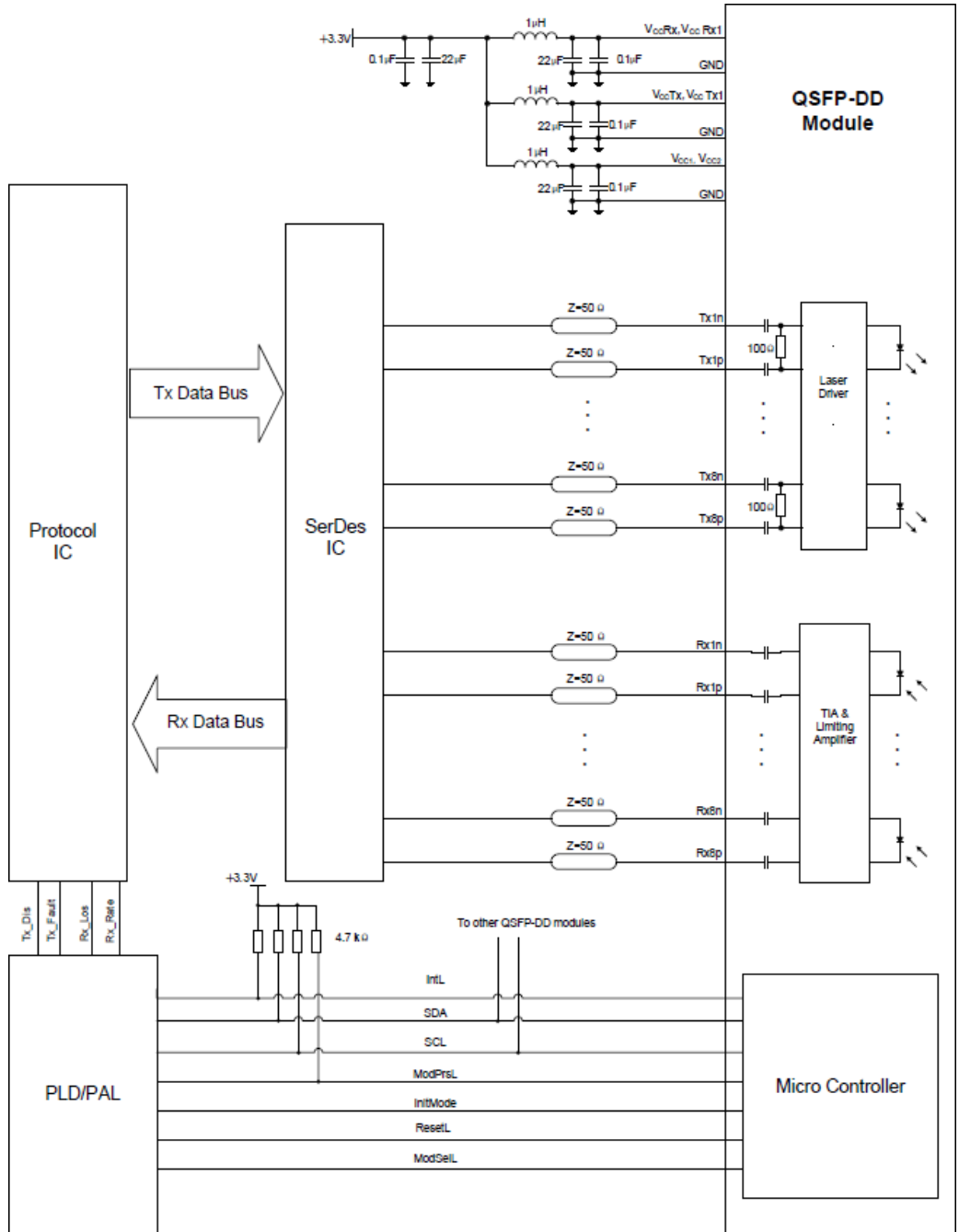

Mechanical Specifications

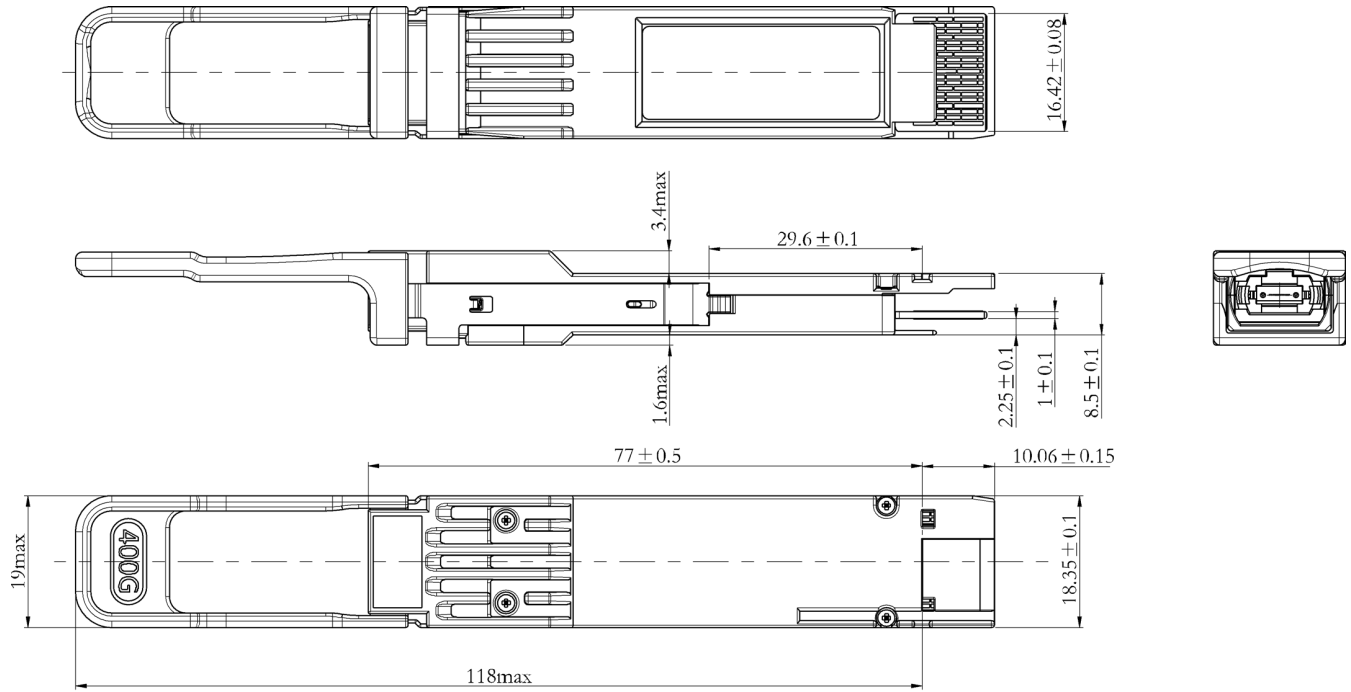

- NOTES:
1.TOLERANCE: +/-0.1MM.
2.OTHERS ACCORDING WITH QSFP-DD MSA OR CUSTOMER SPEC.
3.LIGHT PORT ACCORDING WITH FIBER CONNECTOR SPEC.

About AddOn Networks

In 1999, AddOn Networks entered the market with a single product. Our founders fulfilled a severe shortage for compatible, cost-effective optical transceivers that compete at the same performance levels as leading OEM manufacturers. Adhering to the idea of redefining service and product quality not previously had in the fiber optic networking industry, AddOn invested resources in solution design, production, fulfillment, and global support.

Combining one of the most extensive and stringent testing processes in the industry, an exceptional free tech support center, and a consistent roll-out of innovative technologies, AddOn has continually set industry standards of quality and reliability throughout its history.

Reliability is the cornerstone of any optical fiber network and is engrained in AddOn's DNA. It has played a key role in nurturing the long-term relationships developed over the years with customers. AddOn remains committed to exceeding industry standards with certifications from ranging from NEBS Level 3 to ISO 9001:2005 with every new development while maintaining the signature reliability of its products.



U.S. Headquarters

Email: sales@addonnetworks.com

Telephone: +1 877.292.1701

Fax: 949.266.9273

Europe Headquarters

Email: salesupportemea@addonnetworks.com

Telephone: +44 1285 842070