



Jafanda LLC.

1309 Coffeen Avenue STE 4304
Sheridan, Wyoming 82801
support@jafanda.com

EPA Est.NO.98581-CHN-1
Made In China



Meets California ozone emissions limit.
CARB CERTIFIED

JAFANDA

JF888 Air Purifier User Manual

Please read the manual carefully and keep it for future reference.
Thank you for choosing us!

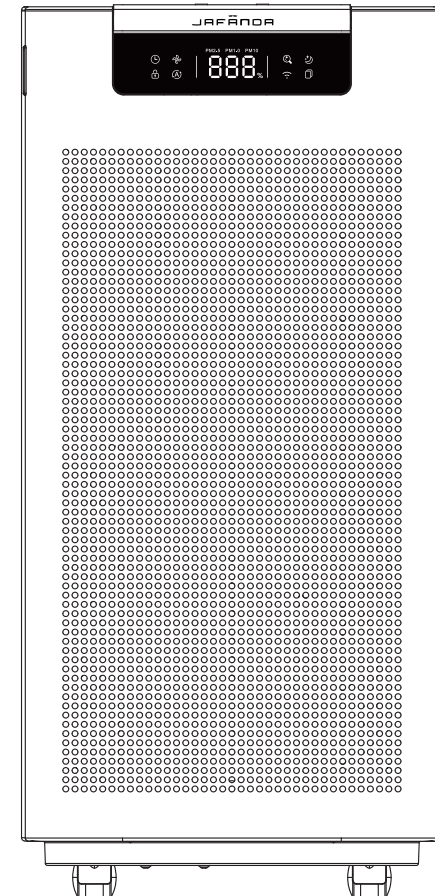

THANK YOU FOR YOUR PURCHASE!

Contact our support team by Email:
support@jafanda.com

Join the jafanda Community on Social Media



@JAFANDA.COM



TABLE OF CONTENTS

Packing Contents	1
Specifications	1
Safety Instructions	2
Know Your Air Purifier	3
Control Panel	4
Product Features	5
Using Your Air Purifier	6-7
Operating Instructions	8
PM Sensor Replacement	9
Cleaning and Maintenance	10
Filter Replacement	11
Troubleshoot Guide	12
Warranty & Support	12
Returns & Refunds	12

Packing Contents

Packing Contents

JF888 Air purifier	1 set
Composite filter	2 pieces (Preinstalled)
Power Cord	1 (in the accessories box)
User Manual	1 (in the accessories box)
App Operation Instructions	1 (in the accessories box)



Specifications





Product specifications

Product Name	Air Purifier	Model	JF888
Rated Voltage	120V~	Product Size	12.2 x 11.4x 25.9 in /31.0x 29.0 x65.7cm
Rated Frequency	60Hz	Package Size	15.08 x 14.3x 29.92 in /38.3x 36.3 x76.0cm
Rated Current	1.2A	N.W	23.1lb/10.5kg
Rated Power	90W	G.W	28.0lb/12.7kg
CADR (Clean Air Delivery Rate)	488CFM(830m³/h)	Standby Power	< 2W
Noise Level	Sleep Mode:22dB High Speed:54dB	Filter Life	3000H
Operating Conditions	Temperature: 14°F -104°F/-10°C -40°C Humidity : 20%-95% RH	Recommended Room Size	760ft²(5 Times/h) 1900ft²(2 Times/h) 3800ft²(1 Times/h)

Safety Instruction

The following safety precautions and instructions must be read carefully and observed when the product is used!

 Prohibitory sign	The behaviors with this sign must be prohibited, otherwise, it may cause product damage or endanger the user's safety.
 Warning sign	The behaviors with this sign must be operated in strict accordance with the requirements, otherwise it may cause product damage or endanger the user's safety.
 Attention sign	The behaviors with this sign must be paid attention to, otherwise, it may cause product damage or other losses due to improper operation.

	Please do not touch the power plug with wet hands.		Please regularly clean the machine and power plug.
	Please do not block the air inlet/outlet.		Only the 120V power sockets are 120V power sockets.
	Please do not use the machine in any place with much oil fume or high humidity.		Please do not put it close to or on any heat source (such as a fireplace, stove, or a place with flammable gases).
	Please do not rinse the high-efficiency composite filter with water.		Please be careful when cleaning the air purifier, as corrosive detergents may damage the surface.
	This machine shall not be used by people with disabilities, perceptual disturbance or diagnosis or children alone, unless they use it under the supervision and guidance of the safety director on the site.		Please do not unplug the power cord from the power socket when cleaning the air purifier or leaving it unused. Otherwise, it may cause an electric shock due to poor insulation or fire due to a short circuit.
	Contains FCC ID: 2ANDL-WBR3 This device complies with part 15 of the FCC Rules. Operation is subject to the following two conditions: (1) This device may not cause harmful interference, (2) this device must accept any interference received, including interference that may cause undesired operation.		
	This air purifier is suitable for floor standing. With caster wheels, it's easy to move in-house. Do not place the air purifier closer than 10cm/4" to wall or another object..		

Know Your Air Purifier

Structure and Name of Product Components

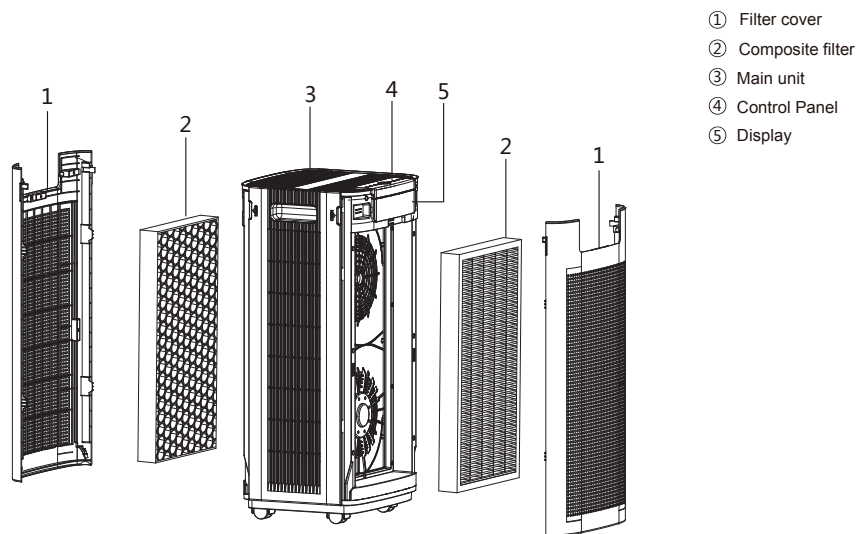

If the picture is inconsistent with the actual product, the latter shall prevail.

Display

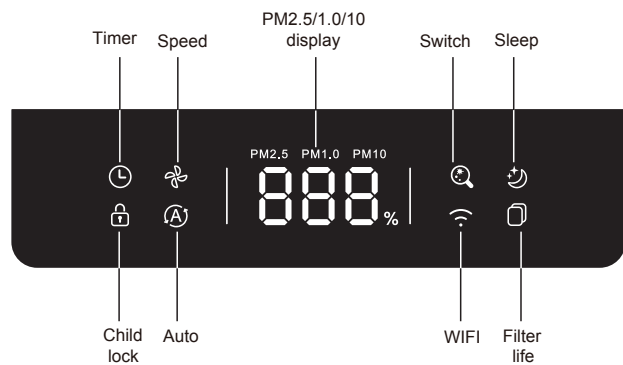

Control Panel

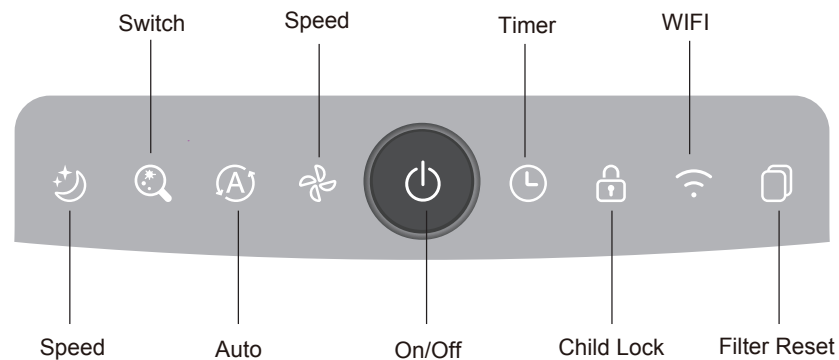

Icons	Icons Name	Introduction
	On/Off	Turns the Air Purifier ON or OFF.
	Speed	Fan speed cycles through 1~5 settings.
	Filter Reset	Press the key of filter life, the white key lights up, and the integrated indication the area displays the percentage of remaining filter life.
	Switch	Switch the PM2.5/PM1.0/PM10 value display (The default value of PM2.5 is displayed.)
	WiFi	Press the WiFi button to connect it to WiFi.
	Auto	In Auto mode, fan speed will be adjusted automatically based on the real-time PM2.5 density.
	Timer	The timer is available from 1 to 24 hours, stopping the operation when the selected time has elapsed.
	Sleep	Press the sleep button in the working state to enter the sleep mode.
	Child Lock	All the other buttons on the control panel are not responsive when the child lock is on.

Product Features

Integration of Multiple Functions

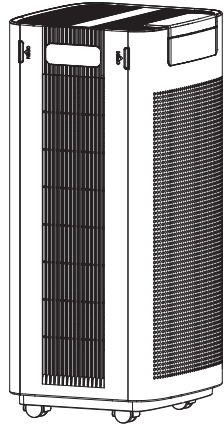

- Efficiently purify PM2.5, smoke, pollen, dust, and other particulate pollutants
- 5 fan speeds
- Timer (0-24H)
- Filter replacement indicator
- Manual, Auto, Sleep, and other operating modes
- Child lock
- Real-time value display of PM2.5/PM1.0/PM10
- WiFi control

3-Stage Filtration

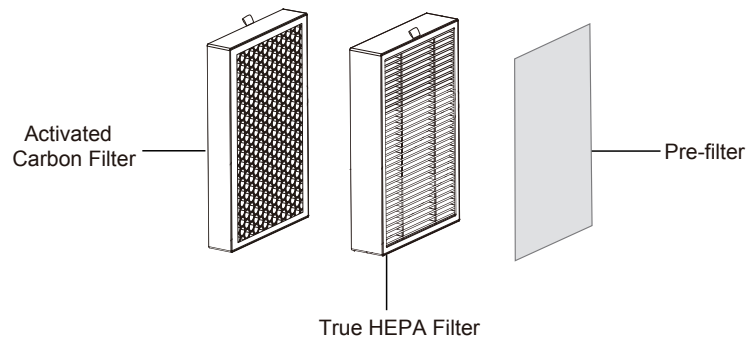

Pre-filter

Captures larger particles such as human hair, fibers, pet fur, and dust particles; Protects the HEPA filter and extends its life.

True HEPA Filter

Removes at least 99.97% of airborne particles 0.3 micrometers (µm) in diameter, Captures particles as small as 0.015 micrometers (µm), Filters small particles such as PM2.5, smoke, pollen, dust, and other pollutants.

Activated Carbon Filter

Absorbs and eliminates fumes and volatile organic compounds in the air.

[Note] The activated carbon filter, True HEPA filter, and Pre-filter are combined in the same filter.

Using Your Air Purifier

- ⚠ Precautions for Use**
- All filters are attached to the air purifier.
 - Please ensure that the filter is installed correctly before use.

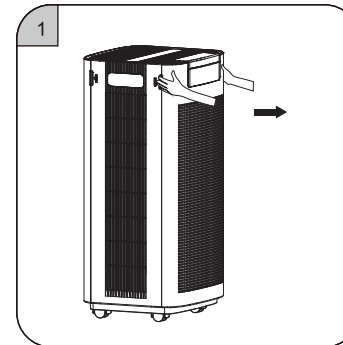

① Pull the filter cover out slightly.

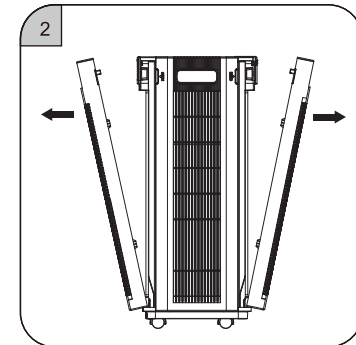

② Take out the filter cover.

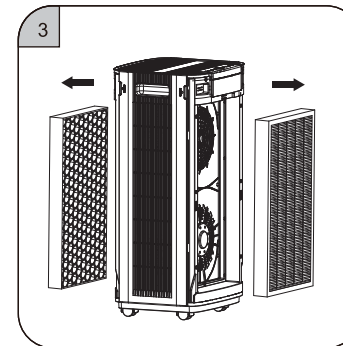

③ Take out the new filter with the plastic film of the machine inside.

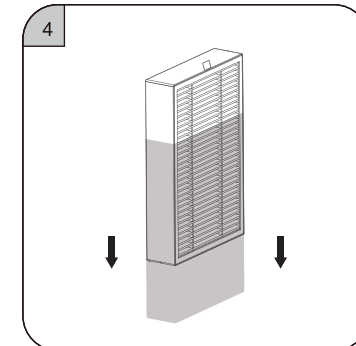

④ Remove the plastic film on the filter.

Using Your Air Purifier

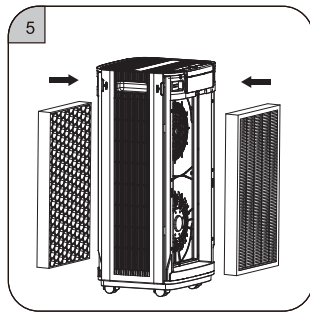

⑤ Put the filter without plastic film back into the machine.

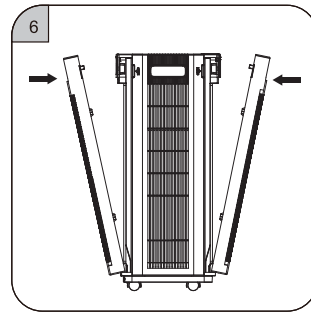

⑥ Put the filter mesh cover back.

Getting Started

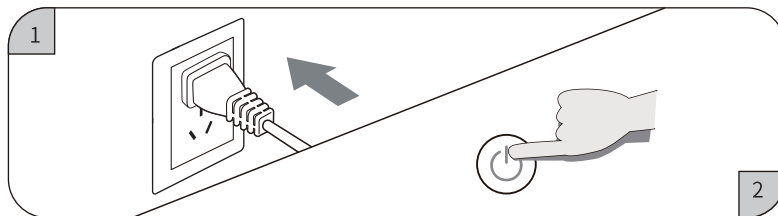

- ① Insert the power plug to make the machine powered on, and the buzzer makes a "ding" sound.
- ② Power on by touching the power key.

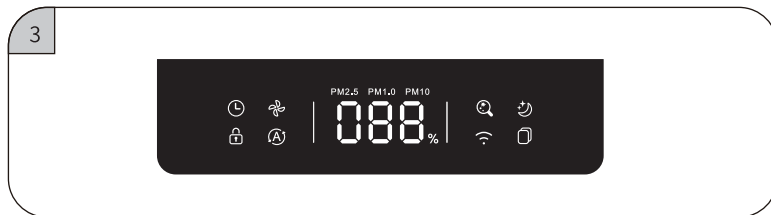

③ The display screen lights up and touches a relevant function button to enter the working state.

Operating Instruction

On/off button

The "⏻" switches the air purifier system on and off. When the system is switched off, the fan stops to run, but the system will remain connected to the power supply (standby mode). The indicator light of the "⏻" is red, and it is white when it is working.

Fan speed button

Touch the "🌀" in the working state, and the indicator light of the button will light up. Every time you touch the "🌀", the gear will change by 1. The gears cycle between 1-5 gears. When adjusting the wind speed, the comprehensive display area on the display will show the wind speed gear.

PM1.0/PM2.5/PM10 AQI

Touch "🔍" in working mode, the button will light up when you press it everytime. The display screen will switch to display the values of PM2.5/PM1.0/PM10. When powered on, the default display is PM2.5. Long touch "🔍" for 5 seconds to switch the temperature display between Fahrenheit and Celsius.

WiFi button

In the power-on state: long press the "📶" for 3 seconds, the WiFi Key indicator light is on and the WiFi icon on the display screen flashes, indicating that it is waiting to connect to the network. After successfully connecting to the network, the WiFi icon on the display is always on, and the button indicator light is always on. If the connection fails within 10 minutes, the WiFi icon goes out and the button indicator light is dark. Every time the power is turned on, the WiFi button lights up and flashes in the power-on state, and the WiFi icon flashes, waiting for network distribution. If there is a distribution network before, it will automatically connect to the mobile phone with the previous distribution network. After the connection is successful, the WiFi button and WiFi icon are always on.

Filter reset button

The filter life is defined as 3000 hours (at 4 wind speeds), the filter life is displayed as a percentage, and the full life is 100%.
Filter Life Check:
 Press the "📊", the comprehensive indicator area will display the percentage of the remaining filter life.
Filter Life Reset:
 Filter life <5%, the filter button flashes red. Remind the user to replace the filter. Press the "📊" more than 3s, and the filter life will display 100%.
 When the life of the filter is ≥5%, long press the "📊" cannot reset the life of the filter, only a "ding" sound will be issued.
Force Filter Life Reset:
 Within 30s of power-on, press and hold the "📊" + "🌙" (more than 3s) at the same time in standby mode, and the life of the filter will be reset, with a "ding" sound, the screen flashes (0.5 seconds/time) 6 times, indicating that the filter life clearing action is completed, press the filter life key to check, and the filter life recovery display is 100%.

Sleep button

Touch the "🌙" in the working state to enter the sleep mode. In the sleep mode, except for the sleep button indicator light and the sleep icon on the display screen, all other button indicator lights and icons are off. The wind speed is running at gear 1, and the sleep button indicator light and the sleep icon on the display will go out after 10 seconds. In sleep mode, touch any function key once to wake up the screen, and the sleep key indicator and sleep icon will light up. Touch any key again to exit sleep mode and return to previous setting mode. In the working state, press and hold the "🌙" for more than 3 seconds to enter the off-screen mode, and all LED indicators go out. The motor runs at the currently set speed. Press any key to exit the off-screen mode, and the display will resume the display of the current machine working status.

Child lock button

In the working state, long press the "🔒" (more than 3 seconds), the child lock function is turned on, the indicator light of the child lock button is on (full light), and the child lock icon on the display is on. When the child lock function is turned on, the functions of touching other touch keys are invalid. Long press the "🔒" again (more than 3 seconds), the child lock function is turned off, the child lock button indicator light is half bright, and other function buttons resume their functions.

Timer button

Timing shutdown:
 touch the "⌚" in the working state, the indicator light of the timing button is on (full light), and it enters the setting state of timing shutdown. The timing icon on the display screen lights up, and the comprehensive display area displays the set time, and the time unit is hours. Every time you touch the "⌚", the value will increase by 1, and the timing value will cycle between 0 and 24. Stop touching the "timing button", the timer shutdown setting is completed, and the set shutdown time will start counting down.
Timing start:
 In the standby state, touch the "⌚", the indicator light of the timing key is on (full light), the timing icon on the display is lit, and it enters the setting state of timing power-on. The comprehensive display area displays the set time, each time you touch the "⌚", the value increases by 1, and the timing value cycles between 0 and 24, and the time unit is hours.

Auto button

Touch the "🔄" in the working state, the working mode is switched between automatic and manual. In the automatic mode, the indicator lights of the automatic keys are on, the indicator lights of other function keys are dark, and the automatic icon on the display is lit. In automatic mode, the wind speed changes according to the value of PM2.5, and the color of the air quality indicator changes according to the value of PM2.5. (the corresponding relation is shown in the following figure).

PM2.5 value	Air quality	PM2.5 air quality indicator	Wind speed gear
0-12	Excellent	Green	1
13-35	Good	Blue	2
36-55	Poor	Yellow	3
>55	Severe	Red	4

PM Sensor Replacement

Replacement of Sensors (Please do not operate by yourself because the sensors must be replaced by professional maintenance personnel)

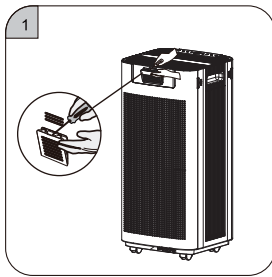

- ① Open the sensor cover with a straight screwdriver.

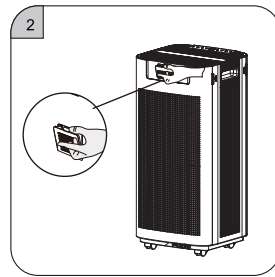

- ② Remove the sensor cover.

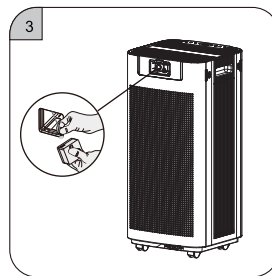

- ③ Hold on to the hardware handle and pull out the sensor module.

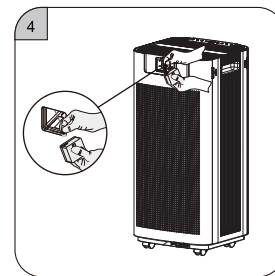

- ④ Unplug the terminal block from the old sensor module and replace it with a new sensor module.

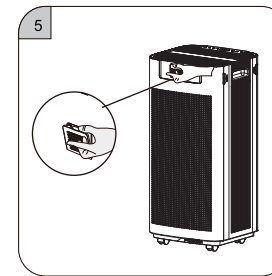

- ⑤ Put back the sensor module and close the sensor cover.

Cleaning and Maintenance

Cleaning and Maintenance

Please unplug the power plug from the adapter before machine maintenance.

1、 Clean the machine body (cleaning once a month is recommended):

- 1) Wipe off stains with a soft rag.
- 2) Wipe off stubborn stains with a soft rag dipped in a proper amount of neutral detergent.

Note: Please avoid scratching the machine shell with any hard object during maintenance. Please operate according to the manual and avoid damaging any machine part during base disassembly.

2、 Clean and change the filter (The Filter life is 3000 hours in normal living environment.):

- 1) The replacement of the filter will be reminded by the built-in program. The filter can also be replaced according to the service life prompt of the filter. It can also be replaced in real-time through the filter life reset function.
- 2) The vacuum cleaner can be used to clean the deposited dust on the surface of the composite filter mesh to prolong the service life of the filter mesh (it is recommended to clean it once every other month and not wash it with water).

*The service life of filter mesh may vary with different environments for using the machine. For example, it will be shortened in smoking areas and areas with pets. Please replace the filter mesh in time when the purification effect becomes worse.

*Please dispose of the used waste filter mesh according to the relevant regulations on solid waste.

Filter replacement

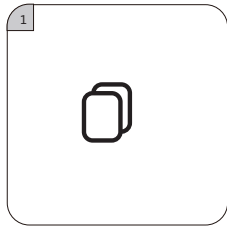

1. When the reset button of filter life lights up in red it prompts that the filter needs to be replaced.

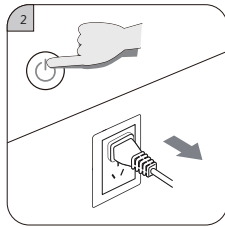

2. Touch the on-off button to power off, and unplug the machine.

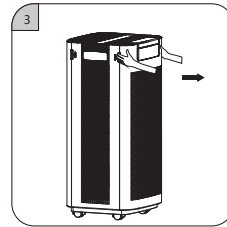

3. Pull the filter cover out slightly.

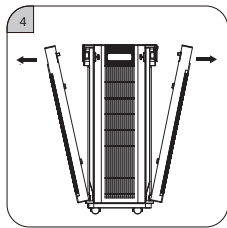

4. Take out the filter cover.

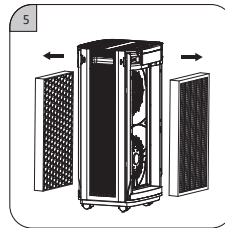

5. Take out the failed filter in the machine.

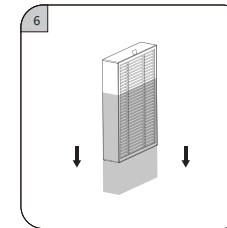

6. Remove the plastic film from the new filter.

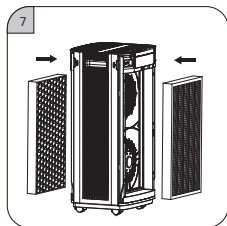

7. Reinstall the new filter in the machine.

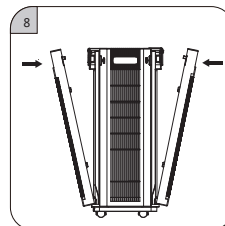

8. Put the filter cover back

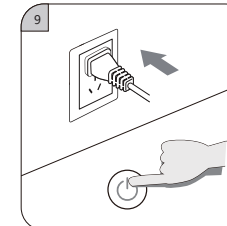

9. Plug in and touch the on-off button .

Troubleshoot Guide

Failures	Possible Causes	Solutions
The product cannot function normally	1. There are problems in connection. 2. The filter cover is not properly installed.	1. Check if the plug is plugged into the socket and if the power button is turned on. 2. Reinstall the filter cover.
The air cannot be ducted smoothly from the air outlet	1. The plastic package of the new filter is not removed. 2. The air outlet of purifier is blocked by foreign matters.	1. Please remove the plastic package first. 2. Clean up foreign matters.
The machine makes noise while functioning	1. The inlet or outlet is blocked by foreign matter. 2. There are foreign matters in the air flue of the machine.	1. Please remove the obstructive matters first. 2. Clean up the foreign matters.
The indicator light for filter change is still flashing after change.	1. The filter reset button has not been pressed.	1. Press and hold the filter button for more than 3 seconds, and complete the filter reset after hearing a prompt tone "ding".
The wind speed seems to decrease	1. The filter life has expired, or the filter is blocked by hair.	1. Clean the dust and hair on the surface with a vacuum cleaner; change the failed filter.
The air purifier gives out an odor	1. The pollutant concentration may be too high, and the filter may reach a saturated state in advance.	1. The filter needs to be changed to avoid secondary pollution.

The most frequently asked questions about this product are listed here. If you cannot find the solution to your question, please contact our after-sales service department.

Warranty & Support

Jafanda products have a **One Year warranty** from the date of purchase and a **Free Extended One -Year warranty** after registering your product with your order and purchase date via <https://www.jafanda.com/pages/warranty-registration>. Jafanda always takes responsibility for all our products. Jafanda always pays high importance to the customer's purchase experience and satisfaction.

Returns & Refunds

If for any reason you are not fully satisfied with your purchase experience within 30 days, we are happy to help with a replacement or refund. For more detail, please visit our after-sales website page: <https://www.jafanda.com/policies/refund-policy>.